

BITSAT

Engineering Entrance Exam Solved Paper 2009

MATHEMATICS

1. $x \in R : \frac{2x-1}{x^3+4x^2+3x} \in R$ Equals
- (a) $R - \{0\}$
 - (b) $R - \{0, 1, 3\}$
 - (c) $R - \{0, -1, -3\}$
 - (d) $R - 0, -1, -3, + \frac{1}{2}$
2. The number of subsets of $\{1, 2, 3, \dots, 9\}$ containing at least one odd number is -
- (a) 324
 - (b) 396
 - (c) 496
 - (d) 512
3. The coefficient of x^{24} in the expansion of $(1 + x^2)^{12}(1 + x^{12})(1 + x^{24})$ is
- (a) ${}^{12}C_6$
 - (b) ${}^{12}C_6 + 2$
 - (c) ${}^{12}C_6 + 4$
 - (d) ${}^{12}C_6 + 6$

4. For $|x| < 1$, the constant term in the expansion of $\frac{1}{x-1} \frac{1}{x-2}$ is
- (a) 2
 (b) 1
 (c) 0
 (d) $-\frac{1}{2}$
5. The roots of $(x - a)(x - a - 1) + (x - a - 1)(x - a - 2) + (x - a)(x - a - 2) = 0$, $a \in \mathbb{R}$ are always
- (a) Equal
 (b) Imaginary
 (c) real and distinct
 (d) rational and equal
6. Let $f(x) = x^2 + ax + b$, where $a, b \in \mathbb{R}$. If $f(x) = 0$ has all its roots imaginary, then the roots of $f(x) + f'(x) + f''(x) = 0$ are
- (a) Real and distinct
 (b) Imaginary
 (c) Equal
 (d) Rational and equal
7. If one of the roots of $\frac{3}{x} + \frac{5}{x} + \frac{x}{7} = 0$ is -10 , then the other roots are

- (a) 3, 7
- (b) 4, 7
- (c) 3, 9
- (d) 3, 4

8. If x, y, z are all positive and are the p th, q th and r th terms of a geometric progression respectively, then the value of the determinant

$$\begin{vmatrix} \log x & p & 1 \\ \log y & q & 1 \\ \log z & r & 1 \end{vmatrix} \text{ equals}$$

- (a) $\log xyz$
- (b) $(p - 1)(q - 1)(r - 1)$
- (c) pqr
- (d) 0

9. If $\begin{vmatrix} 1 & -1 & x \\ 1 & x & 1 \\ x & -1 & 1 \end{vmatrix}$ has no inverse, then the real value of x is

- (a) 2
- (b) 3
- (c) 0
- (d) 1

10. The locus of z satisfying the inequality $\frac{z+2i}{2z+i} < 1$, where $z = x + iy$, is

- (a) $x^2 + y^2 < 1$

- (b) $x^2 - y^2 < 1$
 (c) $x^2 + y^2 > 1$
 (d) $2x^2 + 3y^2 < 1$

11. The period of $\sin^4 x + \cos^4 x$ is

- (a) $\frac{\pi^4}{2}$
 (b) $\frac{\pi^2}{2}$
 (c) $\frac{\pi}{4}$
 (d) $\frac{\pi}{2}$

12. $\frac{\cos x}{\cos x - 2y} = \lambda \Rightarrow \tan x - y \tan y$ is equal to

- (a) $\frac{1+\lambda}{1-\lambda}$
 (b) $\frac{1+\lambda}{1+\lambda}$
 (c) $\frac{\lambda}{1+\lambda}$
 (d) $\frac{\lambda}{1-\lambda}$

13. $\cos A \cos 2A \cos 4A \dots \cos 2^{n-1} A$ equals

- (a) $\frac{\sin 2^n A}{2^n \sin A}$
 (b) $\frac{2^n \sin 2^n A}{\sin A}$
 (c) $\frac{2^n \sin A}{\sin 2^n A}$

(d) $\frac{\sin A}{2^n \sin 2^n A}$

14. If $3 \cos x \neq -2 \sin x$, then the general solution of $\sin^2 x - \cos 2x = 2 - \sin 2x$ is

(a) $n\pi + (-1)^n \frac{\pi}{2}, n \in \mathbb{Z}$

(b) $\frac{n\pi}{2}, n \in \mathbb{Z}$

(c) $4n \pm 1 \frac{\pi}{2}, n \in \mathbb{Z}$

(d) $2n - 1 \pi, n \in \mathbb{Z}$

15. In a ΔABC

$\frac{a+b+c}{4b^2c^2} \frac{b+c-a}{4b^2c^2} \frac{c+a-b}{4b^2c^2} \frac{a+b-c}{4b^2c^2}$ equals

(a) $\cos^2 A$

(b) $\cos^2 B$

(c) $\sin^2 A$

(d) $\sin^2 B$

16. P is a point on the segment joining the feet of two vertical poles of heights a and b. The angles of elevation of the tops of the poles from P are 45° each. Then, the square of the distance between the tops of the poles is

(a) $\frac{a^2 + b^2}{2}$

(b) $a^2 + b^2$

(c) $2(a^2 + b^2)$

(d) $4(a^2 + b^2)$

17. In a quadrilateral ABCD, the point P divides DC in the ratio 1:2 and Q is the mid point of AG. If $AB + 2AD + BC - 2DC = k PQ$, then k is equal to

- (a) - 6
- (b) - 4
- (c) 6
- (d) 4

18. If m_1, m_2, m_3 and m_4 are respectively the magnitudes of the vectors

$$a_1 = 2i - j + k, a_2 = 3i - 4j - 4k,$$

$$a_3 = i + j - k \text{ and } a_4 = -i + 3j + k,$$

then the correct order of m_1, m_2, m_3 and m_4 is

- (a) $m_3 < m_1 < m_4 < m_2$
- (b) $m_3 < m_1 < m_2 < m_4$
- (c) $m_3 < m_4 < m_1 < m_2$
- (d) $m_3 < m_4 < m_2 < m_1$

19. The volume of the tetrahedron having the edges $i + 2j - k, i + j + k, i - j + \lambda k$ as coterminous, is $\frac{2}{3}$ cubic unit. Then λ equals

- (a) 1
- (b) 2
- (c) 3
- (d) 4

20. If A and B are events of a random experiment such that $P(A \cup B) = \frac{4}{5}$, $P(A \cup \bar{B}) = \frac{7}{10}$ and $P(B) = \frac{2}{5}$, then P(A) equals
- (a) $\frac{9}{10}$
- (b) $\frac{8}{10}$
- (c) $\frac{7}{10}$
- (d) $\frac{3}{5}$
21. If X is a binomial variate with the range {a, 1, 2, 3, 4, 5, 6} and $P(X = 2) = 4P(X = 4)$, then the parameter p of X is
- (a) $\frac{1}{3}$
- (b) $\frac{1}{2}$
- (c) $\frac{2}{3}$
- (d) $\frac{3}{4}$
22. The area (in square unit) of the circle which touches the lines $4x + 3y = 15$ and $4x + 3y = 5$ is
- (a) 4π
- (b) 3π
- (c) 2π
- (d) π
23. The point on the line $3x + 4y = 5$ which is equidistant from (1,

- 2) and (3, 4) is
- (a) (7, - 4)
 - (b) (15, -10)
 - (c) (1/7, 8/7)
 - (d) (0, 5/4)
24. The equation of the straight line perpendicular to the straight line $3x + 2y = 0$ and passing through the point of intersection of the lines $x + 3y - 1 = 0$ and $x - 2y + 4 = 0$ is
- (a) $2x - 3y + 1 = 0$
 - (b) $2x - 3y + 3 = 0$
 - (c) $2x - 3y + 5 = 0$
 - (d) $2x - 3y + 7 = 0$
25. The value of λ with $|\lambda| < 16$ such that $2x^2 - 10xy + 12y^2 + 5x + \lambda y - 3 = 0$ represents a pair of straight lines, is
- (a) -10
 - (b) -9
 - (c) 10
 - (d) 9
26. The area (in square unit) of the triangle formed by $x + y + 1 = 0$ and the pair of straight lines $x^2 - 3xy + 2y^2 = 0$ is
- (a) 7/12
 - (b) 5/12
 - (c) 1/12

- (d) $1/6$
27. The pairs of straight lines $x^2 - 3xy + 2y^2 = 0$ and $x^2 - 3xy + 2y^2 + x - 2 = 0$ form a
- (a) Square but not rhombus
 - (b) Rhombus
 - (c) Parallelogram
 - (d) Rectangle but not a square
28. The equations of the circle which pass through the origin and makes intercepts of lengths 4 and 8 on the x and y-axes respectively are
- (a) $x^2 + y^2 \pm 4x \pm 8y = 0$
 - (b) $x^2 + y^2 \pm 2x \pm 4y = 0$
 - (c) $x^2 + y^2 \pm 8x \pm 16y = 0$
 - (d) $x^2 + y^2 \pm x \pm y = 0$
29. The locus of centre of a circle which passes through the origin and cuts off a length of 4 unit from the line $x = 3$ is
- (a) $y^2 + 6x = 0$
 - (b) $y^2 + 6x = 13$
 - (c) $y^2 + 6x = 10$
 - (d) $x^2 + 6y = 13$
30. The point $(3, -4)$ lies on both the circles $x^2 + y^2 - 2x + 8y + 13 = 0$ and $x^2 + y^2 - 4x + 6y + 11 = 0$ Then, the angle between the circles is -

- (a) 60°
- (b) $\tan^{-1} \frac{1}{2}$
- (c) $\tan^{-1} \frac{3}{5}$
- (d) 135°
31. The equation of the circle which passes through the origin and cuts orthogonally each of the circles $x^2 + y^2 - 6x + 8 = 0$ and $x^2 + y^2 - 2x - 2y = T$ is
- (a) $3x^2 + 3y^2 - 8x - 13y = 0$
- (b) $3x^2 + 3y^2 - 8x + 29y = 0$
- (c) $3x^2 + 3y^2 + 8x + 29y = 0$
- (d) $3x^2 + 3y^2 - 8x - 29y = 0$
32. The number of normals drawn to the parabola $y^2 = 4x$ from the point $(1, 0)$ is
- (a) 0
- (b) 1
- (c) 2
- (d) 3
33. If the circle $x^2 + y^2 = a^2$ intersects the hyperbola $xy = c^2$ in four points (x_i, y_i) , for $i = 1, 2, 3$ and 4 , then $y_1 + y_2 + y_3 + y_4$ equals
- (a) 0
- (b) c
- (c) a

(d) c^4

34. The mid point of the chord $4x - 3y = 5$ of the hyperbola $2x^2 - 3y^2 - 12$ is

(a) $0, -\frac{5}{3}$

(b) $2, 1$

(c) $\frac{5}{4}, 0$

(d) $\frac{11}{4}, 2$

35. If a line in the space makes angle α , β and γ with the coordinate axes, then

$\cos 2\alpha + \cos 2\beta + \cos 2\gamma + \sin^2 \alpha + \sin^2 \beta + \sin^2 \gamma$ equals

(a) -1

(b) 0

(c) 1

(d) 2

36. The image of the point $(3, 2, 1)$ in the plane $2x - y + 3z = 7$ is

(a) $(1, 2, 3)$

(b) $(2, 3, 1)$

(c) $(3, 2, 1)$

(d) $(2, 1, 3)$

37. $\lim_{x \rightarrow \infty} \frac{x+5}{x+2}^{x+3}$ equals

- (a) e
- (b) e^2
- (c) e^3
- (d) e^5

38. If $f: \mathbb{R} \rightarrow \mathbb{R}$ is defined by

$f(x) = \begin{cases} \frac{2 \sin x - \sin 2x}{2x \cos x}, & \text{if } x \neq 0 \\ a, & \text{if } x = 0 \end{cases}$, then the value of a so that f is continuous at 0 is

- (a) 2
- (b) 1
- (c) -1
- (d) 0

39. $x = \frac{1-\bar{y}}{1+\bar{y}} \Rightarrow \frac{dy}{dx}$ is equal to

- (a) $\frac{4}{x+1}^2$
- (b) $\frac{4x-1}{1+x}^3$
- (c) $\frac{x-1}{1+x}^3$
- (d) $\frac{4}{x+1}^3$

40. $\frac{d}{dx} a \tan^{-1} x + b \log \frac{x-1}{x+1} = \frac{1}{x^4-1} \Rightarrow a - 2b$ is equal to

- (a) 1
 (b) -1
 (c) 0
 (d) 2
41. $y = e^{a \sin^{-1} x} \Rightarrow (1 - x^2) y_{n+2} - (2n + 1) xy_{n+1}$ is equal to
 (a) $-(n^2 + a^2)y_n$
 (b) $(n^2 - a^2)y_n$
 (c) $(n^2 + a^2) y_n$
 (d) $-(n^2 - a^2) y_n$
42. The function $f(x) = x^3 + ax^2 + bx + c, a^2 \leq 3b$ has
 (a) one maximum value
 (b) one minimum value
 (c) no extreme value
 (d) one maximum and one minimum value
43. $\int \frac{2 - \sin 2x}{1 - \cos 2x} e^x dx$ is equal to
 (a) $-e^x \cot x + c$
 (b) $e^x \cot x + c$
 (c) $2e^x \cot x + c$
 (d) $-2e^x \cot x + c$
44. $\int_0^{\pi} \frac{1}{1 + \sin x} dx$ is equal to

- (a) 1
(b) 2
(c) -1
(d) -2
45. The solution of the differential equation $\frac{dy}{dx} = \sin x + y \tan x + y - 1$ is
- (a) $\operatorname{cosec}(x + y) + \tan(x + y) = x + c$
(b) $x + \operatorname{cosec}(x + y) = c$
(c) $x + \tan(x + y) = c$
(d) $x + \sec(x + y) = c$

Physics

46. When a wave traverses a medium the displacement of a particle located at x at a time is given by $y = a \sin(bt - cx)$, where a , b and c are constants of the wave, which of the following is a quantity with dimensions?
- (a) $\frac{y}{a}$
(b) bt
(c) cx
(d) $\frac{b}{c}$
47. A body is projected vertically upwards at time $t = 0$ and it is seen at a height H at time t_1 and t_2 second during its flight. The maximum height attained is (g is acceleration due to gravity)

(a) $\frac{g t_2 - t_1^2}{8}$

(b) $\frac{g t_1 + t_2^2}{4}$

(c) $\frac{g t_1 + t_2^2}{8}$

(d) $\frac{g t_2 - t_1^2}{4}$

48. A particle is projected up from a point at an angle θ with the horizontal direction. At any time t , if P is the linear momentum, y is the vertical displacement, x is horizontal displacement, the graph among the following which does not represent the variation of kinetic energy KE of the particle is

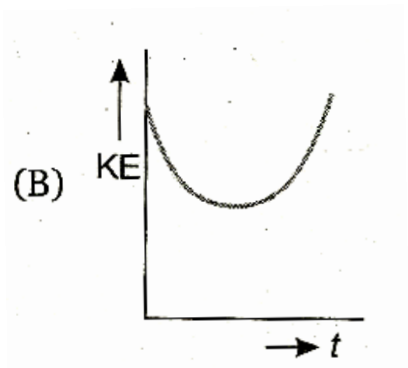
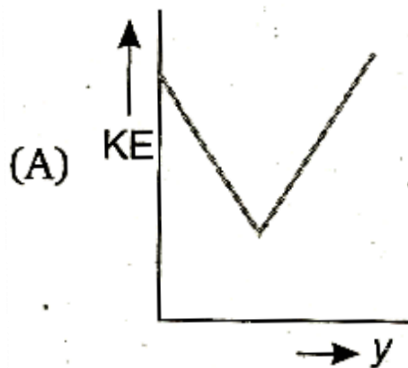

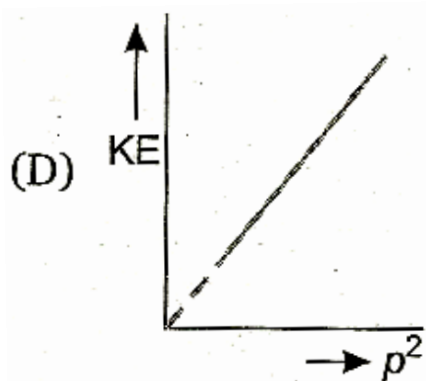
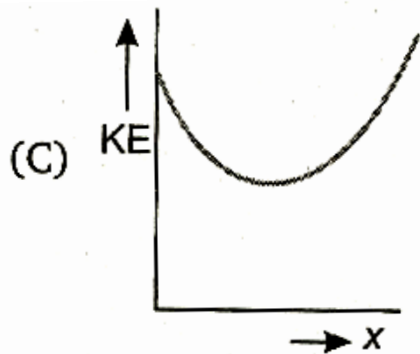

- (a) graph (A)
- (b) graph (B)
- (c) graph (C)
- (d) graph (D)

49. A motor of power P_0 is used to deliver water at a certain rate through a given horizontal pipe. To increase the rate of flow of water through the same pipe n times, the power of the motor is increased to P_1 . The ratio of P_1 to P_0 is

- (a) $n: 1$
- (b) $n^2: 1$
- (c) $n^3: 1$

- (d) $n^4: 1$
50. A body of mass 5 kg makes an elastic collision with another body at rest and continues to move in the original direction after collision with a velocity equal to 1/10th of its original velocity. Then the mass of the second body is
- (a) 4.09 kg
 (b) 0.5 kg
 (c) 5 kg
 (d) 5.09 kg
51. A particle of mass 4 m explodes into three pieces, of masses m, m and 2 m. The equal masses move along X-axis and Y-axis with velocities 4 ms^{-1} and 6 ms^{-1} respectively. The magnitude of the velocity of the heavier mass is
- (a) $\sqrt{17} \text{ ms}^{-1}$
 (b) $2\sqrt{13} \text{ ms}^{-1}$
 (c) $\sqrt{13} \text{ ms}^{-1}$
 (d) $\frac{\sqrt{13}}{2} \text{ ms}^{-1}$
52. body is projected vertically upwards from the surface of the earth with a velocity equal to half the escape velocity. If R is the radius of the earth, maximum height attained by the body from the surface of the earth is
- (a) $R/6$
 (b) $R/3$
 (c) $2R/3$

(d) R

53. The displacement of a particle executing SHM is given by

$$y = 5 \sin 4t + \frac{\pi}{3} .$$

If T is the time period and the mass of the particle is 2 g, the kinetic energy of the particle when $t = \frac{T}{4}$ is given by

- (a) 0.4 J
- (b) 0.5 J
- (c) 3 J
- (d) 0.3 J

54. If the ratio of lengths, radii and Young's modulus of steel and brass wires shown in the figure are a, b and c respectively, the ratio between the increase in lengths of brass and steel wires would be

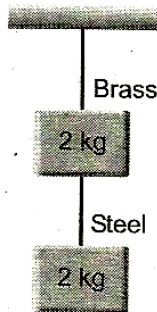

- (a) $\frac{b^2 a}{2c}$
- (b) $\frac{bc}{2a^2}$
- (c) $\frac{ba^2}{2c}$

- (d) $\frac{a}{24\pi T r^2}$
55. A soap bubble of radius r is blown up to form a bubble of radius $2r$ under isothermal conditions. If T is the surface tension of soap solution, the energy spent in the blowing
- (a) $3\pi T r^2$
(b) $6\pi T r^2$
(c) $12\pi T r^2$
(d) $24\pi T r^2$
56. Eight spherical rain drops of the same mass and radius are falling down with a terminal speed of 6 cm s^{-1} . If they coalesce to form one big drop, what will be the terminal speed of bigger drop? (Neglect the buoyancy of the air)
- (a) 1.5 cm-s^{-1}
(b) 6 cm -s^{-1}
(c) 24 cm-s^{-1}
(d) 32 cm-s^{-1}
57. A clock pendulum made of invar has a period of 0.5 s , at 20°C . If the clock is used in a climate where the temperature averages to 30°C , how much time does the clock lose in each oscillation?
(For invar, $\alpha = 9 \times 10^{-7} / ^\circ\text{C}$, $g = \text{constant}$)
- (a) $2.25 \times 10^{-6}\text{ s}$
(b) $2.5 \times 10^{-7}\text{ s}$
(c) $5 \times 10^{-7}\text{ s}$
(d) $1.125 \times 10^{-6}\text{ s}$

58. A piece of metal weighs 45 g in air and 25 g in a liquid of density $1.5 \times 10^3 \text{ kg-m}^{-3}$ kept at 30°C .

When the temperature of the liquid is raised to 40°C , the metal piece weighs 27 g. The density of liquid at 40°C is $1.25 \times 10^3 \text{ kg-m}^{-3}$. The coefficient of linear expansion of metal is

- (a) $1.3 \times 10^{-3}/^\circ\text{C}$
(b) $5.2 \times 10^{-3}/^\circ\text{C}$
(c) $2.6 \times 10^{-3}/^\circ\text{C}$
(d) $0.26 \times 10^{-3}/^\circ\text{C}$
59. An ideal gas is subjected to a cyclic process ABCD as depicted in the p- V diagram given below:

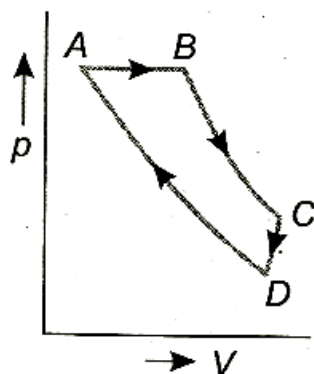

Which of the following curves represents the equivalent cyclic process?

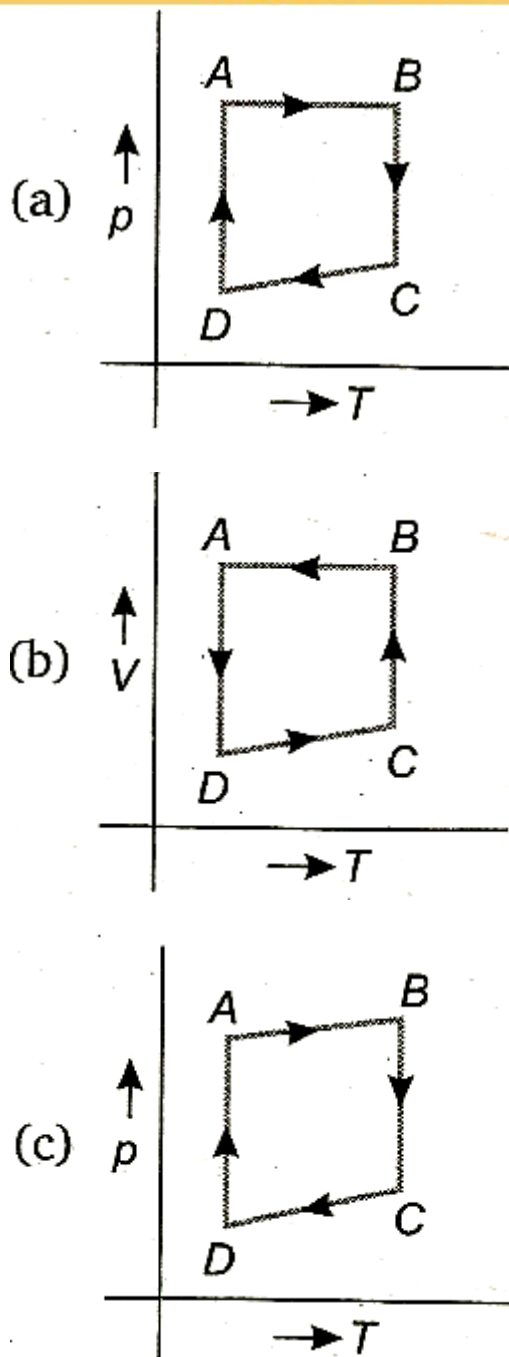

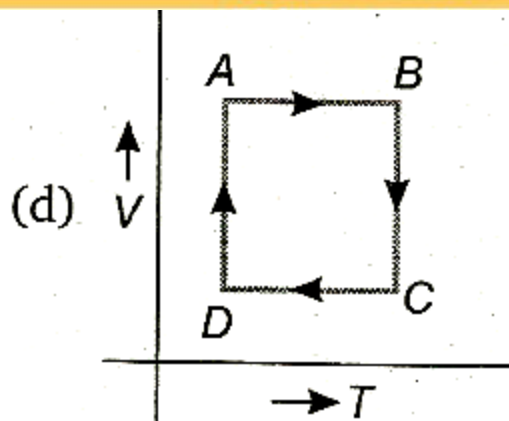

60. An ideal gas is subjected to cyclic process involving four thermodynamic states, the amounts of heat (Q) and work (W) involved in each of these states are

$$Q_1 = 6000 \text{ J},$$

$$Q_2 = -5500 \text{ J};$$

$$Q_3 = -3000 \text{ J};$$

$$Q_4 = 3500 \text{ J}$$

$$W_1 = 2500 \text{ J};$$

$$W_2 = -1000 \text{ J};$$

$$W_3 = -1200 \text{ J};$$

$$W_4 = x \text{ J}.$$

The ratio of the net work done by the gas to the total heat absorbed by the gas is η . The values of x and η respectively are

- (a) 500; 7.5%
 (b) 700; 10.5%
 (c) 1000; 21%
 (d) 1500; 15%

61. Two cylinders A and B fitted with pistons contain equal number of moles of an ideal mono atomic gas at 400 K. The piston of A is free to move while that of B is held fixed. Same amount of heat energy is given to the gas in each cylinder. If the rise in temperature of the gas in A is 42 K, the rise in temperature of the gas in B is
- (a) 21 K
(b) 35 K
(c) 42 K
(d) 70 K
62. Three rods of same dimensional have thermal conductivity 3 K, 2 K and K. They are arranged as shown in the figure below

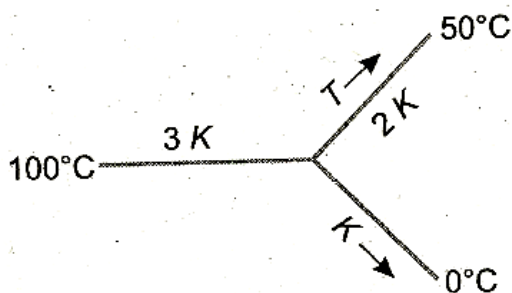

Then, the temperature of the junction in steady state is

- (a) $\frac{200}{3}^\circ\text{C}$
(b) $\frac{100}{3}^\circ\text{C}$
(c) 75°C
(d) $\frac{50}{3}^\circ\text{C}$

63. Two sources A and B are sending notes of frequency 680 Hz. A listener moves from A and B with-a constant velocity u . If the speed of sound in air is 340 ms^{-1} , what must be the value of u so that he hears 10 beats per second?
- (a) 2.0 ms^{-1}
 - (b) 2.5 ms^{-1}
 - (c) 3.0 ms^{-1}
 - (d) 3.5 ms^{-1}
64. Two identical piano wires have a fundamental frequency of 600 cycle per second when kept under the same tension. What fractional increase in the tension of one wires will lead to the occurrence of 6 beats per second when both wires vibrate simultaneously?
- (a) 0.01
 - (b) 0.02
 - (c) 0.03
 - (d) 0.04
65. In the Young's double slit experiment, the intensities at two points P_1 and P_2 on the screen are respectively I_1 and I_2 , If P_1 is located at the centre of a bright fringe and P_2 is located at a distance equal to a quarter of fringe width from P_1 , then $\frac{I_1}{I_2}$ is
- (a) 2
 - (b) $\frac{1}{2}$
 - (c) 4

(d) 16

66. In Young's double slit experiment, the 10th maximum of wavelength λ_1 is at a distance of y_1 from the central maximum. When the wavelength of the source is changed to λ_2 , 5th maximum is at a distance of y_2 from its central maximum. The ratio $\frac{y_1}{y_2}$ is

(a) $\frac{2\lambda_1}{\lambda_2}$

(b) $\frac{2\lambda_2}{\lambda_1}$

(c) $\frac{\lambda_1}{2\lambda_2}$

(d) $\frac{\lambda_2}{2\lambda_1}$

67. Four light sources produce the following four waves:

(i) $y_1 = a' \sin (\omega t + \phi_1)$

(ii) $y_2 = a' \sin 2\omega t$

(iii) $y_3 = a' \sin (\omega t + \phi_2)$

(iv) $y_4 = a' \sin (3 \omega t + \phi)$

Super Position of which two waves give rise to interference?

(a) (i) and (ii)

(b) (ii) and (iii)

(c) (i) and (iii)

(d) (iii) and (iv)

68. The two lenses of an achromatic doublet should have

- (a) Equal powers
 - (b) Equal dispersive powers
 - (c) Equal ratio of their power and dispersive power
 - (d) Sum of the product of their powers and dispersive power equal to zero
69. Two bar magnets A and B are placed one over the other and are allowed to vibrate in a vibration magnetometer. They make 20 oscillations per minute when the similar poles of A and B are on the same side, while they make 15 oscillations per minute when their opposite poles lie on the same side. If M_A and M_B are the magnetic moments of A and B and if $M_A > M_B$, the ratio of M_A and M_B is
- (a) 4: 3
 - (b) 25:7
 - (c) 7: 5
 - (d) 25: 16
70. A bar magnet is 10 cm long is kept with its north (N)-pole pointing north. A neutral point is formed at a distance of 15 cm from each pole:
- Given the horizontal component of earth's field is 0.4 Gauss, the pole strength of the magnet is
- (a) 9 A-m
 - (b) 6.75 A-m
 - (c) 27 A-m
 - (d) 1.35 A-m

71. An infinitely long thin straight wire has uniform linear charge density of $\frac{1}{3} \text{ cm}^{-1} \text{ cm}^{-1}$. Then, the magnitude of the electric intensity at a point 18 cm away is

(given $\epsilon_0 = 8.8 \times 10^{-12} \text{ C}^2\text{Nm}^{-2}$)

(a) $0.33 \times 10^{11} \text{ NC}^{-1}$

(b) $3 \times 10^{11} \text{ NC}^{-1}$

(c) $0.66 \times 10^{11} \text{ NC}^{-1}$

(d) $1.32 \times 10^{11} \text{ NC}^{-1}$

72. Two point charges $-q$ and $+q$ are located at point's $(0, 0, -a)$ and, $(0, 0, a)$ respectively. The electric potential at a point $(0, 9, z)$, where $z > a$ is

(a) $\frac{qa}{4\pi\epsilon_0 z^2}$

(b) $\frac{q}{4\pi\epsilon_0 a}$

(c) $\frac{2qa}{4\pi\epsilon_0 z^2 - a^2}$

(d) $\frac{2qa}{4\pi\epsilon_0 z^2 + a^2}$

73. In the adjacent shown circuit, a voltmeter of internal resistance R , when connected across B and C reads $\frac{100}{3} \text{ V}$.

Neglecting the internal resistance of the battery, the value of R is

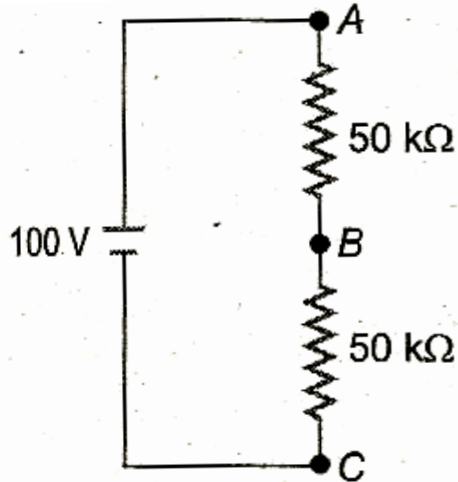

- (a) 100 kΩ
- (b) 75 kΩ
- (c) 50 kΩ
- (d) 25 kΩ

74. A cell in secondary circuit gives null deflection for 2.5 m length of potentiometer having 10 m length of wire. If the length of the potentiometer wire is increased by 1 m without changing the cell in the primary, the position of the null point now is -

- (a) 3.5 m
- (b) 3 m
- (c) 2.75 m
- (d) 2.0 m

75. The following series L-C-R circuit, when driven by an emf source of angular frequency 70 kilo-radians per second, the circuit effectively behaves like

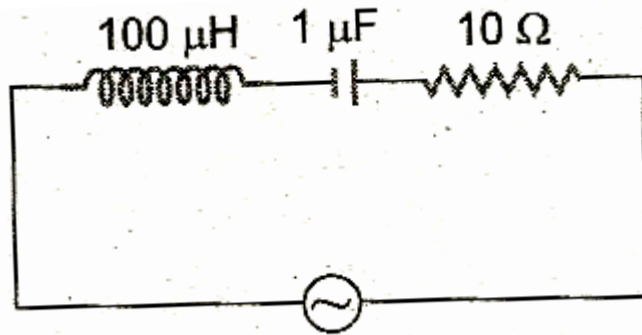

- (a) Purely resistive circuit
 (b) Series R-L circuit
 (c) Series R-C circuit
 (d) Series L-C circuit with $R = 0$
76. A wire of length l is bent into a circular loop of radius R and carries a current I . The magnetic field at the centre of the loop is B . The same wire is now bent into a double loop of equal radii. If both loops carry the same current I and it is in the same direction, the magnetic field at the centre of the double loop will be –
- (a) Zero
 (b) $2B$
 (c) $4B$
 (d) $8B$
77. An infinitely long straight conductor is bent into the shape as shown below. It carries a current of I ampere and the radius of the circular loop is R metre. Then, the magnitude of magnetic induction at the centre of the circular loop is –

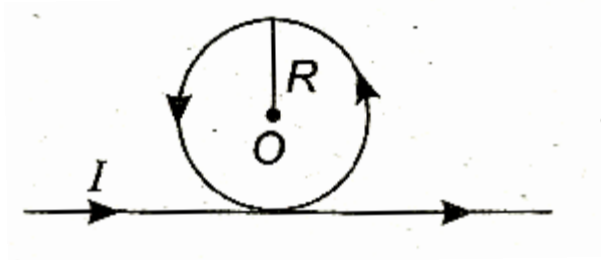

- (a) $\frac{\mu_0 I}{2\pi R}$
- (b) $\frac{\mu_0 nI}{2R}$
- (c) $\frac{\mu_0 I}{2\pi R} \pi + 1$
- (d) $\frac{\mu_0 I}{2\pi R} \pi - 1$
76. The work function of a certain metal is 3.31×10^{-19} J. Then, the maximum kinetic energy of photoelectrons emitted by incident radiation of wavelength 5000 Å is
(Given, $h = 6.62 \times 10^{-34}$ J-s,
 $c = 3 \times 10^8$ ms⁻¹. $e = 1.6 \times 10^{-19}$ C)
- (a) 248 eV
- (b) 0.41 eV
- (c) 2.07 eV
- (d) 0.82 eV
79. A photon of energy E ejects; a photoelectron from a metal surface whose work function is W_0 . If this electron enters into a uniform magnetic field of induction B in a direction perpendicular to the field and describes a circular path of radius r , then the radius r is given by, (in the usual notation)
- (a) $\frac{2m \sqrt{E - W_0}}{eB}$

(b) $\frac{2m E - W_0}{eB}$

(c) $\frac{2e E - W_0}{mB}$

(d) $\frac{2m E - W_0}{eB}$

80. Two radioactive materials X_1 and X_2 have decay constants 10λ and λ respectively. If initially they have the same number of nuclei, then the ratio of the number of nuclei of X_1 to that of X_2 will be $1/e$ after a time

(a) $(1/10\lambda)$

(b) $1/(11\lambda)$

(c) $11/(10\lambda)$

(d) $1/(9\lambda)$

81. Currents flowing in each of the following circuits A and B respectively are

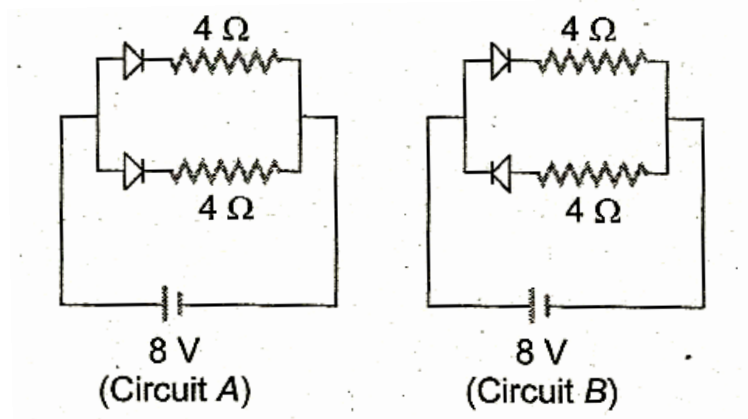

(a) 1 A, 2 A

(b) 2 A, 1 A

(c) 4 A, 2 A

- (d) 2 A, 4 A
82. A bullet of mass 0.02 kg travelling horizontally with velocity 250 ms^{-1} strikes a block of wood of mass 0.23 kg which rests on a rough horizontal surface. After the impact, the block and bullet move together and come to rest after travelling a distance of 40 m. The coefficient of sliding friction of the rough surface is ($g = 9.8 \text{ ms}^{-2}$)
- (a) 0.75
 (b) 0.61
 (c) 0.51
 (d) 0.30
83. Two persons A and B are located in X - Y plane at the points (0, 0) and (0, 10) respectively. (The distances are measured in MKS unit). At a time $t = 0$, they start moving simultaneously with velocities $v_A = 2j \text{ ms}^{-1}$ and $v_B = 2i \text{ ms}^{-1}$ respectively. The time after which A and B are at their closest distance is
- (a) 2.5 s
 (b) 4 s
 (c) 1 s
 (d) $\frac{10}{2} \text{ s}$
84. A rod of length l is held vertically stationary with its lower end located at a point P, on the horizontal plane. When the rod is released to topple about P, the velocity of the upper end of the rod with which it hits the ground is
- (a) $\frac{g}{l}$

(b) $\overline{3gl}$

(c) $3 \frac{g}{l}$

(d) $\overline{\frac{3g}{l}}$

85. A wheel of radius 0.4 m can rotate freely about its axis as shown in the figure. A string is wrapped over its rim and a mass of 4 kg is hung. An angular acceleration of 8 rad-s^{-2} is produced in it due to the torque. Then, moment of inertia of the wheel is ($g = 10 \text{ ms}^{-2}$)

(a) 2 kg-m^2

(b) 1 kg-m^2

(c) -4 kg-m^2

(d) 8 kg-m^2

CHEMISTRY

86. Given that $\Delta H_f(\text{H}) = 218 \text{ kJ/mol}$, express the H-H bond energy in kcal/mol.

(a) 52.15

(b) 911

(c) 104

(d) 52153

87. Identify the alkyne in the following sequence of reactions,

TransWeb Educational Services Pvt. Ltd.

B – 147, 1st Floor, Sector-6, NOIDA, U.P. -201301

Website: <http://www.askitians.com> Email: info@askitians.com

Tel: 0120-4616500 Ext – 213

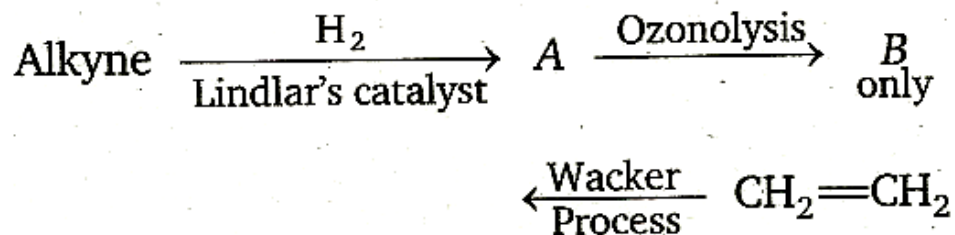

- (a) $\text{H}_3\text{C} - \text{C} \equiv \text{C} - \text{CH}_3$
- (b) $\text{H}_3\text{C} - \text{CH}_2 - \text{C} \equiv \text{CH}$
- (c) $\text{H}_2\text{C} = \text{CH} - \text{C} \equiv \text{CH}$
- (d) $\text{HC} = \text{C} - \text{CH}_2 - \text{C} \equiv \text{CH}$
88. Fluorine reacts with dilute NaOH and forms a gaseous product A. The bond angle in the molecule of A is
- (a) $104^\circ 40'$
- (b) 103°
- (c) 107°
- (d) $109^\circ 28'$
89. One mole of alkene X on ozonolysis gave one mole of acetaldehyde and one mole of acetone. The IUPAC name of X is
- (a) 2-methyl-2-butene
- (b) 2-methyl-1-butene
- (c) 2-butene
- (d) 1-butene
90. The number of $p\pi-d\pi$ 'pi' bonds present in XeO_3 and XeO_4 molecules, respectively are

- (a) 3, 4
(b) 4, 2
(c) 2, 3
(d) 3, 2
91. The wavelengths of electron waves in two orbits is 3: 5. The ratio of kinetic energy of electrons will be
(a) 25: 9
(b) 5: 3
(c) 9: 25
(d) 3: 5
92. Which one of the following sets correctly represents the increase in the paramagnetic property of the ions?
(a) $\text{Cu}^{2+} > \text{V}^{2+} > \text{Cr}^{2+} > \text{Mn}^{2+}$
(b) $\text{Cu}^{2+} < \text{Cr}^{2+} < \text{V}^{2+} < \text{Mn}^{2+}$
(c) $\text{Cu}^{2+} < \text{V}^{2+} < \text{Cr}^{2+} < \text{Mn}^{2+}$
(d) $\text{V}^{2+} < \text{Cu}^{2+} < \text{Cr}^{2+} < \text{Mn}^{2+}$
93. Electrons with a kinetic energy of 6.023×10^4 J/mol are evolved from the surface of a metal, when it is exposed to radiation of wavelength of 600 nm. The minimum amount of energy required to remove an electron from the metal atom is
(a) 2.3125×10^{19} J
(b) 3×10^{-19} J
(c) 6.02×10^{-19} J
(d) 6.62×10^{-34} J

94. The chemical entities present in thermosphere of the atmosphere are
- (a) O^{+2}, O^+, NO^+
 - (b) O_3
 - (c) N_2, O_2, CO_2, H_2O
 - (d) O_3, O^+_2, O_2
95. The type of bonds present in sulphuric anhydride are -
- (a) 3σ and three $p\pi - d\pi$
 - (b) 3σ one $p\pi - p\pi$ and two $p\pi - d\pi$
 - (c) 2σ and three $p\pi - d\pi$
 - (d) 2σ and two $p\pi - d\pi$
96. In Gattermann reaction, a diazonium group is replaced by X using Y X and Y are -
- | <u>X</u> | <u>Y</u> |
|------------------|--------------|
| (a) Cl^\ominus | Cu/HCl |
| (b) Cl^\oplus | $CuCl_2/HCl$ |
| (c) Cl^\oplus | $CuCl_2/HCl$ |
| (d) Cl_2 | Cu_2O/HCl |
97. Which pair of oxyacids of phosphorus contains 'P-H' bonds?
- (a) H_3PO_4, H_3PO_3
 - (b) $H_3PO_3, H_4P_2O_7$

- (c) $\text{H}_3\text{PO}_3, \text{H}_3\text{PO}_2$
- (d) $\text{H}_3\text{PO}_2, \text{HPO}_3$
98. Dipole moment of $\text{HCl} = 1.03 \text{ D}$, $\text{HI} = 0.38 \text{ D}$. Bond length of $\text{HCl} = 1.3 \text{ \AA}$ and $\text{HI} = 1.6 \text{ \AA}$. The ratio of fraction of electric charge δ , existing on each atom in HCl and HI is
- (a) 12: 1
- (b) 2.7: 1
- (c) 3.3: 1
- (d) 1: 3.3
99. SiCl_4 on hydrolysis forms 'X' and HCl . Compound 'X' loses water at 1000°C and gives 'Y'. Compounds 'X' and 'Y' respectively are
- (a) $\text{H}_2\text{SiCl}_6, \text{SiO}_2$
- (b) $\text{H}_4\text{SiO}_4, \text{Si}$
- (c) SiO_2, Si
- (d) $\text{H}_4\text{SiO}_4, \text{SiO}_2$
100. 1.5 g of CdCl_2 was found to contain 0.9 g of Cd . Calculate the atomic weight of Cd .
- (a) 118
- (b) 112
- (c) 106.5
- (d) 53.25

101. Aluminium reacts with NaOH and forms compound 'X'. If the coordination number of aluminium in 'X' is 6, the correct formula of X is
- $[\text{Al}(\text{H}_2\text{O})_4(\text{OH})_2]^+$
 - $[\text{Al}(\text{H}_2\text{O}_3)(\text{OH})_3]$
 - $[\text{Al}(\text{H}_2\text{O})_2(\text{OH})_4]^-$
 - $[\text{Al}(\text{H}_2\text{O})_6](\text{OH})_3$
102. The average kinetic energy of one molecule of an ideal gas at 27°C and 1 atm pressure is
- 900 cal K⁻¹ mol⁻¹
 - 6.21×10^{-21} JK⁻¹ molecule⁻¹
 - 336.7 JK⁻¹ molecule⁻¹
 - 3741.3 JK⁻¹ mol⁻¹
103. **Assertion (A)** K, Rb and Cs form superoxides. Reason (R) The stability of the superoxides increases from 'K' to 'Cs' due to decrease in lattice energy.
- The correct answer is
- Both (A) and (R) are true and (R) is the correct explanation of (A)
 - Both (A) and (R) are true but (R) is not the correct explanation of (A)
 - (A) is true but (R) is not true
 - (A) is not true but (R) is true
104. How many 'mL' of perhydrol is required to produce sufficient oxygen which can be used to completely convert 2L of SO₂ gas

- to SO_3 gas?
- (a) 10 mL
 (b) 5 mL
 (c) 20 mL
 (d) 30 mL
105. pH of a buffer solution decreases by 0.02 units when 0.12 g of acetic acid is added to 250 mL of a buffer solution of acetic acid and potassium acetate at 27°C . The buffer capacity of the solution is
- (a) 0.1
 (b) 10
 (c) 1
 (d) 0.4
106. Match the following.

List I		List II	
(A)	Flespar	(I)	$[\text{Ag}_3\text{SbS}_3]$
(B)	Asbestos	(II)	$\text{Al}_2\text{O}_3 \cdot \text{H}_2\text{O}$
(C)	Pyrrargyrite	(III)	$\text{MgSO}_4 \cdot \text{H}_2\text{O}$
(D)	Diaspore	(IV)	KAlSi_3O_8
		(V)	$\text{CaMg}_3(\text{SiO}_3)_4$

The correct answer is

- | | (A) | (B) | (C) | (D) |
|-----|-----|-----|-----|-----|
| (a) | IV | V | II | I |
| (b) | IV | V | I | II |
| (c) | IV | I | III | II |
| (d) | II | V | IV | I |

107. Which one of the following order is correct for the first ionisation energies of the elements?

- (a) B < Be < N < O
 (b) Be < B < N < O
 (c) B < Be < O < N
 (d) B < O < Be < N

108. What are X and Y in the following reaction sequence?

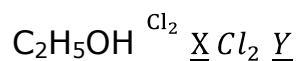

- (a) C₂H₅Cl, CH₃CHO
 (b) CH₃CHO, CH₃CO₂H
 (c) CH₃CHO, CCl₃CHO
 (d) C₂H₅Cl, CCl₃CHO

109. What are A, B, C in the following reactions?

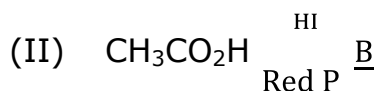
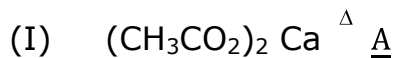

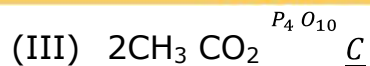

	<u>A</u>	<u>B</u>	<u>C</u>
(a)	C_2H_6	CH_3COCH_3	$(\text{CH}_3\text{CO})_2\text{O}$
(b)	$(\text{CH}_3\text{CO})_2\text{O}$	C_2H_6	CH_3COCH_3
(c)	CH_3COCH_3	C_2H_6	$(\text{CH}_3\text{CO})_2\text{O}$
(d)	CH_3COCH_3	$(\text{CH}_3\text{CO})_2\text{O}$	C_2H_6

110. One per cent composition of an organic compound A is, carbon: 85.71% and hydrogen 14.29%. Its vapour density is 14. Consider the following reaction sequence

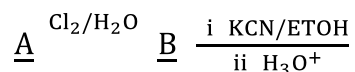

Identify C

- (a) $\text{CH}_3 - \text{CH} - \text{CO}_2\text{H}$
 $\quad \quad \quad |$
 $\quad \quad \quad \text{OH}$
- (b) $\text{HO} - \text{CH}_2 - \text{CH}_2 - \text{CO}_2\text{H}$
- (c) $\text{HO} - \text{CH}_2 - \text{CO}_2\text{H}$
- (d) $\text{CH}_3 - \text{CH}_2 - \text{CO}_2\text{H}$

111. How many tripeptides can be prepared by linking the amino acids glycine, alanine and phenyl alanine?

- (a) One

- (b) Three
- (c) Six
- (d) Twelve

112. A codon has a sequence of A, and specifies a particular B that is to be incorporated into a C. What are A, B, C?

- | | <u>A</u> | <u>B</u> | <u>C</u> |
|-----|----------|--------------|--------------|
| (a) | 3 bases | amino acid | carbohydrate |
| (b) | 3 acids | carbohydrate | protein |
| (c) | 3 bases | protein | amino acid |
| (d) | 3 bases | amino acid | protein |

113. Parkinson's disease is linked to abnormalities in the levels of dopamine in the body. The structure of dopamine is –

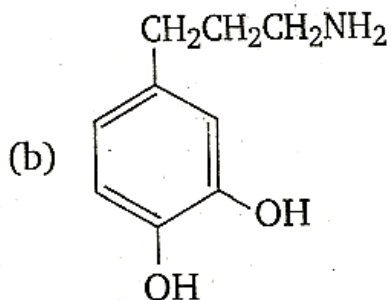
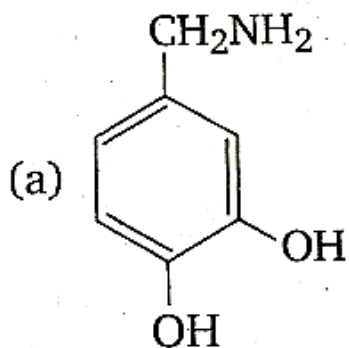

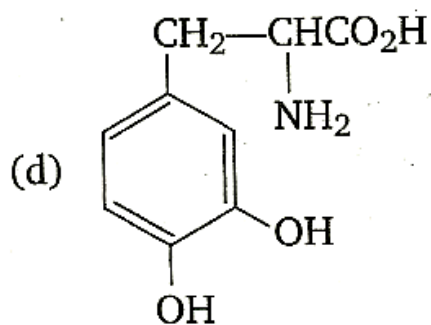
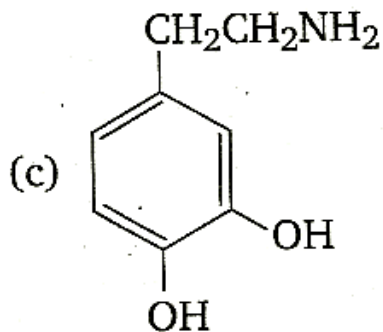

114. During the depression in freezing point experiment, an equilibrium is established between the molecules of -

- (a) Liquid solvent and solid solvent
- (b) Liquid solute and solid solvent
- (c) Liquid solute and solid solute
- (d) Liquid solvent and solid solute

115. Consider the following reaction,

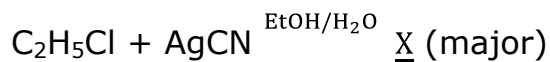

Which one of the following statements is true for X?

- (I) It gives propionic acid on hydrolysis
- (II) It has an ester functional group

- (III) It has a nitrogen linked to ethyl carbon
- (IV) It has a cyanide group
- (a) IV
- (b) III
- (c) II
- (d) I

116. For the following cell reaction,



$$\Delta G_f^\ominus / (\text{AgCl}) = -109 \text{ kJ/mol}$$

$$\Delta G_f^\ominus / (\text{Cl}^\ominus) = -129 \text{ kJ/mol}$$

$$\Delta G_f^\ominus / (\text{Ag}^+) = 78 \text{ kJ/mol}$$

E^\ominus of the cell is

- (a) - 0.60 V
 - (b) 0.60 V
 - (c) 6.0 V
 - (d) None of these
117. The synthesis of crotonaldehyde from acetaldehyde is an example of reaction
- (a) nucleophilic addition
 - (b) elimination
 - (c) electrophilic addition
 - (d) nucleophilic addition-elimination

118. At 25°C, the molar conductances at infinite dilution for the strong electrolytes NaOH, NaCl and BaCl₂ are 248×10^{-4} , 126×10^{-4} and $280 \times 10^{-4} \text{ Sm}^2 \text{ mol}^{-1}$ respectively, $\lambda_m^\circ \text{ Ba(OH)}_2$ in $\text{Sm}^2 \text{ mol}^{-1}$ is –

- (a) 52.4×10^{-4}
- (b) 524×10^{-4}
- (c) 402×10^{-4}
- (d) 262×10^{-4}

119. The cubic unit cell of a metal (molar mass = 63.55 g mol^{-1}) has an edge length of 362 pm.

Its density is 8.92 g cm^{-3} the type of unit cell is

- (a) Primitive
- (b) Face centred
- (c) Body centred
- (d) End centred

120. The equilibrium constant for the given reaction is 100.

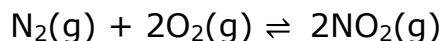

What is the equilibrium constant for the reaction given below?

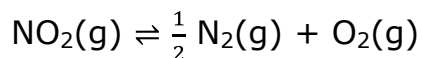

- (a) 10
- (b) 1
- (c) 0.1

- (d) 0.01
121. For a first order reaction at 27°C, the ratio of time required for 75% completion to 25% completion of reaction is –
- (a) 3.0
(b) 2.303
(c) 4.8
(d) 0.477
122. The concentration of an organic compound in chloroform is 6.15 g per 100 mL of solution. A portion of this solution in a 5 cm polarimeter' tube causes an observed rotation of -1.2° . What is the specific rotation of the compound?
- (a) $+12^\circ$
(b) -3.9°
(c) -39°
(d) $+61.5^\circ$
123. 20 mL of 0.1 M acetic acid is mixed with 50 mL of potassium acetate. K_a of acetic acid = 1.8×10^{-5} at 27°C. Calculate concentration of potassium acetate if pH of the mixture is 4.8.
- (a) 0.1 M
(b) 0.04 M
(c) 0.4 M
(d) 0.02 M

124. Calculate ΔH° for the reaction,

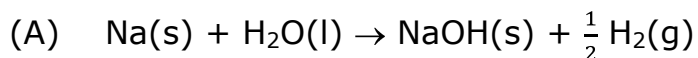

$$\Delta H^\circ = -146 \text{ kJ}$$

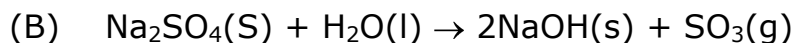

$$\Delta H^\circ = + 418 \text{ kJ}$$

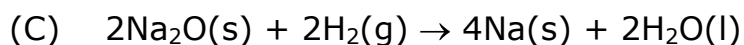

$$\Delta H^\circ = + 259 \text{ kJ}$$

(a) + 823 kJ

(b) -581 kJ

(c) -435 kJ

(d) +531 kJ

125. Which one of the following is most effective in causing the coagulation of an As_2S_3 sol?

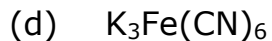

REASONING

Directions (Q. 126-128): In each of the following questions, choose the most appropriate alternative to fill in the blank.

TransWeb Educational Services Pvt. Ltd.

B – 147, 1st Floor, Sector-6, NOIDA, U.P. -201301

Website: <http://www.askitians.com> Email: info@askitians.com

Tel: 0120-4616500 Ext – 213

126. It is difficult to believe what he tells us because his account of any event is always full of of all sorts.
- (a) Discrepancies
 - (b) Differences
 - (c) Discretions
 - (d) Distinctions
127. The bank clerk tried to money from his friend's account.
- (a) Empower
 - (b) Embellish
 - (c) Embroil
 - (d) Embezzle
128. Eight scientists have the national awards for outstanding contribution and dedication to the profession-
- (a) Bestowed
 - (b) Picked
 - (c) Bagged
 - (d) Conferred

Directions (Q. 129-131): In the following questions, some parts have been jumbled up. You are required to rearrange these parts, which are labelled P, Q, R and S, to produce the correct sentence.

129. Freedom, is the restricted kind in the sense/(P), the rich and

poor woman/(Q), that a wide gulf separates/ (R), which a modern woman enjoys(S)

- (a) P S R Q
- (b) S R Q P
- (c) R Q P S
- (d) S P R Q

130. In life, some rules are/(P), as in business/(Q), they seem almost instinctive/(R), learnt so early that/(S)

- (a) R S P Q
- (b) Q P S R
- (c) R P S Q
- (d) Q S P R

131. Kapil, left in an aeroplane/(P), after reading a sailing magazine/(Q), had decided/(R), to build his own boat nine years earlier/(S)

- (a) P R Q S
- (b) R S Q P
- (c) R Q P S
- (d) P S R Q

Directions (Q. 132-134): In each of the following questions is choose the alternative which is most nearly the same in meaning to the word given in capital letters.

132. DENOUEMENT

- (a) Outcome
- (b) Eschew
- (c) Action
- (d) Character

133. GAUCHE

- (a) Vain
- (b) Rich
- (c) Polished
- (d) Tactless

134. ACCOLADE

- (a) Honour
- (b) Appreciation
- (c) Greeting
- (d) Gift

Directions (Q. 135-137): In each of the following questions, choose the alternative which is opposite in meaning to the word given in capital letters.

135. REPRIMAND

- (a) Reward

- (b) Appreciate
- (c) Encourage
- (d) Praise

136. IMPERTINENT

- (a) Polite
- (b) Indifferent
- (c) Unpleasant
- (d) Stubborn

137. EQUIVOCAL

- (a) Mistaken
- (b) Quaint
- (c) Clear
- (d) Universal

Directions (Q. 138-140): In each of the following questions, choose the alternative which can be substituted for the given words/sentence.

138. Design made by putting together coloured pieces of glass or stones –
- (a) Oleograph
 - (b) Mosaic
 - (c) Tracery
 - (d) Relief

139. The doctrine that human soul passes from one body to another at the time of death

- (a) Metamorphosis
- (b) Transition
- (c) Transmigration
- (d) Extrapolation

140. A style in which a writer makes a display of his knowledge

- (a) Pedantic
- (b) Ornate
- (c) Verbose
- (d) Pompous

Directions (Q. 141): In each of these questions, two figure/words are given to the left of the sign :: and one figures word to the right of the sign:: with four alternatives under it out. of which one of the alternatives has the same relationship with the figures/words to the right of the sign:: as between the two figures/words to the left of the sign (::). Find the correct alternative.

141.

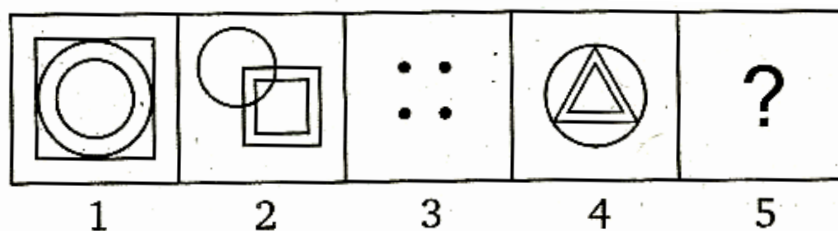

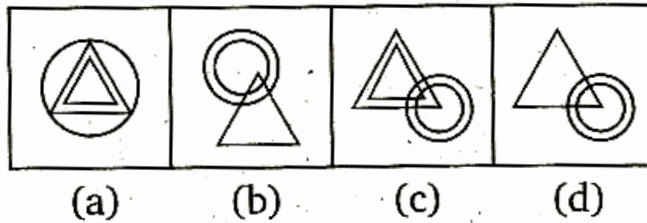

Directions (Q. 142): In the following question, choose the missing word or sign (?) on the basis of the relationship between the words given on the left/right hand side of the signs.

142. Doctor: Nurse:: ? : Follower

- (a) Worker
- (b) Employer
- (c) Union
- (d) Leader

143. One of the, numbers does not fit into the series.

Find the wrong number

1788, 892, 444, 220, 112, 52, 24

- (a) 52
- (b) 112
- (c) 220
- (d) 444

Directions (Q. 144): In the question below is given a statement followed by three assumptions numbered I, II and III. An assumption is something supposed or taken for granted. You

have to consider the statement and the following assumptions and decide which of the assumption(s) is/are implicit in the statement.

144. **Statement:** Large number of people affected by the flood in the area gathered at the relief camp for food, water and shelter organized by the state government

Assumptions:

- I. The relief camp has enough supplies to provide food and water to the affected people in the area.
 - II. All those whose houses are submerged can be accommodated in the temporary shelters.
 - III. Many more affected people are yet to reach the relief camp.
- (a) Only I is implicit
 - (b) Only I and II are implicit
 - (c) Only II is implicit
 - (d) Only II and III are implicit

145. Identify the missing part of the figure and select it from the given alternatives.

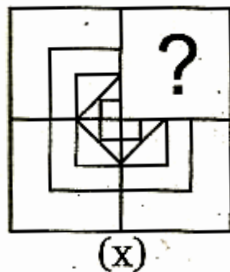

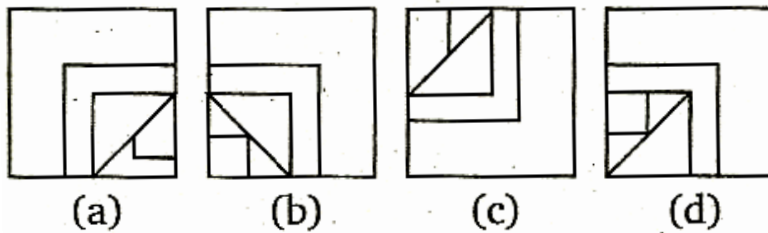

146. Figure (x) is embedded in any one of the four alternative figures. Choose the alternative which contains figure (x).

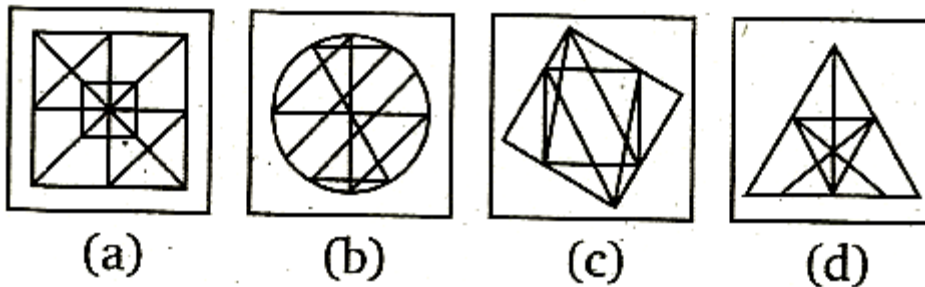
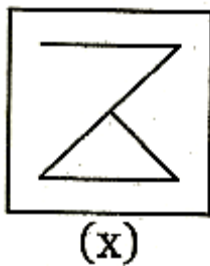

147. Which symbol will appear on the opposite surface to the symbol x?

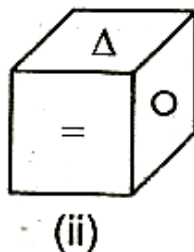
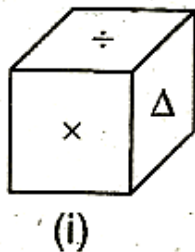

- (a) '÷'
- (b) 'x'
- (c) '+'
- (d) '-'

148. The three figures marked X, Y, Z show the manner in which a paper is folded step by step and then cut. From the answer figures (a), (b), (c), (d), select the one, showing the unfolded position of the Paper after the cut.

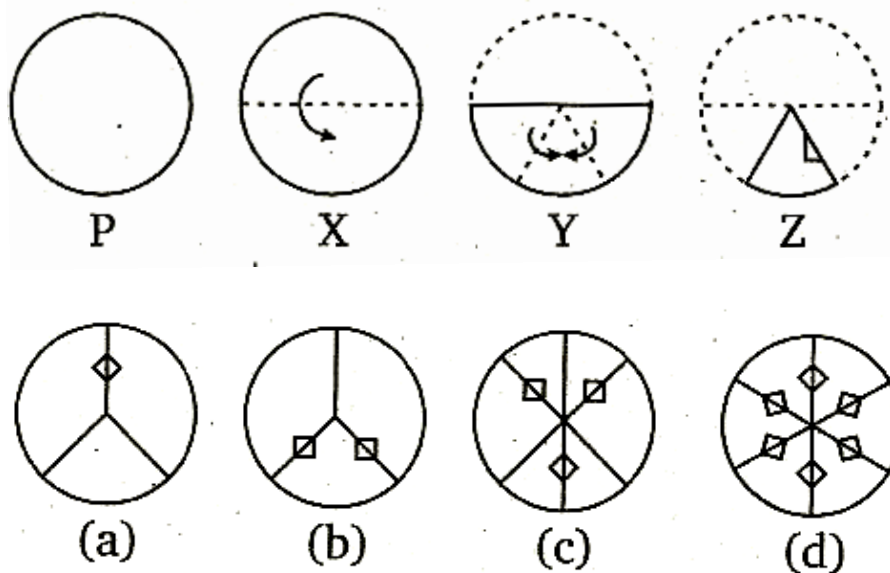

149. SERVANT: QGPXYPR :: KING?

- (a) MKPI
- (b) IKLI
- (c) IGLE
- (d) IGPI

149. If P denotes ' \div '

Q denotes, ' \times '

R denotes '+'

S denotes '-',

Then what is the value of $18 Q 12 P 4 R 5 S 6 = ?$

(a) 64

(b) 81

(c) 53

(d) 24

Answers

TransWeb Educational Services Pvt. Ltd.

B – 147, 1st Floor, Sector-6, NOIDA, U.P. -201301

Website: <http://www.askitians.com> Email. info@askitians.com

Tel: 0120-4616500 Ext – 213

MATHEMATICS

1. (c)	2. (c)
3. (b)	4. (d)
5. (c)	6. (b)
7. (a)	8. (d)
9. (d)	10. (c)
11. (d)	12. (b)
13. (a)	14. (c)
15. (c)	16. (c)
17. (a)	18. (a)
19. (a)	20. (c)
21. (a)	22. (d)
23. (b)	24. (d)
25. (b)	26. (c)
27. (c)	28. (a)
29. (b)	30. (d)
31. (b)	32. (b)
33. (a)	34. (b)
35. (c)	36. (c)
37. (c)	38. (d)
39. (b)	40. (b)
41. (c)	42. (c)
43. (a)	44. (b)

TransWeb Educational Services Pvt. Ltd.

B – 147, 1st Floor, Sector-6, NOIDA, U.P. -201301

Website: <http://www.askitians.com> Email: info@askitians.com

Tel: 0120-4616500 Ext – 213

45. (b)	
----------------	--

PHYSICS

46. (d)	47. (c)
48. (a)	49. (a)
50. (a)	51. (c)
52. (b)	53. (d)
54. (d)	55. (d)
56. (c)	57. (a)
58. (c)	59. (a)
60. (b)	61. (c)
62. (a)	63. (b)
64. (b)	65. (d)
66. (a)	67. (c)
68. (d)	69. (b)
70. (d)	71. (a)
72. (c)	73. (c)
74. (c)	75. (c)
76. (c)	77. (c)
78. (b)	79. (d)
80. (d)	81. (c)
82. (c)	83. (a)
84. (b)	85. (a)

CHEMISTRY

86. (c)	87. (a)
88. (b)	89. (a)
90. (a)	91. (a)
92. (c)	93. (a)
94. (a)	95. (b)
96. (a)	97. (c)
98. (c)	99. (d)
100. (c)	101. (c)
102. (b)	103. (c)
104. (a)	105. (d)
106. (b)	107. (c)
108. (c)	109. (c)
110. (b)	111. (c)
112. (d)	113. (c)
114. (a)	115. (b)
116. (a)	117. (d)
118. (b)	119. (b)
120. (c)	121. (c)
122. (c)	123. (b)

TransWeb Educational Services Pvt. Ltd.

B – 147, 1st Floor, Sector-6, NOIDA, U.P. -201301

Website: <http://www.askitians.com> Email. info@askitians.com

Tel: 0120-4616500 Ext – 213

124. (b)

125. (b)

REASONING

126. (a)	127. (d)
128. (c)	129. (d)
130. (b)	131. (b)
132. (a)	133. (d)
134. (b)	135. (b)
136. (a)	137. (c)
138. (b)	139. (c)
140. (a)	141. (d)
142. (d)	143. (b)
144. (b)	145. (b)
146. (b)	147. (d)
148. (b)	149. (a)
150. (c)	