

SUMMATIVE ASSESSMENT - I
SCIENCE
Class - X

Time allowed: 3 hours

Maximum Marks: 90

General Instructions :

- (i) The question paper comprises of **two Sections, A and B**. You are to attempt both the sections.
- (ii) **All questions are compulsory.**
- (iii) There is no overall choice. However, internal choice has been provided. Only one option in such questions is to be attempted.
- (iv) **All questions of Section-A and all questions of Section-B** are to be attempted separately.
- (v) Question numbers **1 to 3** in **Section-A** are **one mark** questions. These are to be answered in **one word** or in **one sentence**.
- (vi) Question numbers **5 to 11** in **Section-A** are **two marks** questions. These are to be answered in about **30 words** each.
- (vii) Question numbers **12 to 23** in **Section-A** are **three marks** questions. These are to be answered in about **50 words** each.
- (viii) Question numbers **24 to 27** in **Section-A** are **five marks** questions. These are to be answered in about **70 words** each.
- (ix) Question numbers **28 to 43** in **Section-B** are multiple choice questions based on practical skills. Each question is a **one mark** question. You are to select one most appropriate response out of the four provided to you.

SECTION-A

1. A few drops of sulphuric acid are added into water before electrolysis. Why ?
2. Give an example of a metal which is a liquid at room temperature.
3. Give one limitation of harnessing energy from Geothermal sources.
4. The resistance of a resistor is kept constant and the potential difference across its two ends is decreased to half of its former value. State the change that will occur in the current through it.
5. What is an alloy ? Give the composition and one use each of the following :
(i) Brass (ii) Solder
6. Name the product obtained by recrystallisation of sodium carbonate and write its chemical formula.
7. (a) A solution of substance 'X' is used for white washing. What is the substance 'X' ? State the chemical reaction of 'X' with water.
(b) Why does the colour of copper sulphate solution change when an iron nail is dipped in it ?
8. (a) Balance the following chemical equations :
 - (i) $\text{BaCl}_2 + \text{H}_2\text{SO}_4 \rightarrow \text{BaSO}_4 + \text{HCl}$
 - (ii) $\text{Ca}(\text{OH})_2 + \text{HNO}_3 \rightarrow \text{Ca}(\text{NO}_3)_2 + \text{H}_2\text{O}$
 - (iii) $\text{Pb}(\text{NO}_3)_2 \rightarrow \text{Pb} + \text{NO}_2 + \text{O}_2$
 - (iv) $\text{MnO}_2 + \text{HCl} \rightarrow \text{MnCl}_2 + \text{H}_2\text{O} + \text{Cl}_2$
9. Stomata of desert plants remain closed during day time. How do they take up carbon dioxide and perform photosynthesis?
10. What is meant by 'ocean thermal energy'? How can electricity be generated from the ocean energy?
11. An electric resistor of resistance 20Ω draws a current of 5A. Calculate the heat produced by it in 30 seconds.

12. A student while studying the force experienced by a current carrying conductor in a magnetic field, records the following observations :
- The force experienced by the conductor increases as the current is increased
 - The force experienced by the conductor decreases as the strength of the magnetic field is increased. Which of the two observations is correct and why ?
13. A thick wire and a thin wire made from same material and of same length are connected one by one to the same source. In which case a larger current will flow in the circuit ? Justify your answer.
14. (a) What is a decomposition reaction ?
(b) What type of reaction will occur when silver chloride is exposed to sun light ?
(c) Identify the type of the reaction, when lead (II) nitrate solution is mixed with potassium iodide solution.
15. (a) How is common salt prepared from sea water?
(b) What will be the approximate pH of the aqueous solutions of the following salts :
(i) Sodium chloride (ii) Ammonium Chloride
16. A white coloured powder is used by the doctors for supporting fractured bones.
- Write chemical name of the powder.
 - Write its formula.
 - Write chemical equation, when this white powder is mixed with water.
17. What is reflex arc ? Draw diagram of reflex arc. Label on it the following :
- Sensory neuron
 - Motor neuron
18. What is geotropism? Describe an experiment to demonstrate positive and negative geotropism.
19. List the disadvantages of using biomass as fuel in the conventional manner. Give two examples of technological input to improve efficiency of these fuels.
20. Derive an expression for the equivalent resistance of the combination of two resistors connected in series.
21. (a) State the function of electric fuse.
(b) An electric bulb is marked 60W. What does this mean ?
How much energy does it consume if used for 1 hour ?
22. What are the advantages of connecting different electrical appliances in parallel ? Mention any three advantages.
23. Write the chemical name and formula of washing soda. How is it prepared? Write balanced chemical equation of the reaction.
24. (i) Write the electron - dot structures for sodium, oxygen and magnesium.
(ii) Show the formation of magnesium oxide by transfer of electrons and name the ions present in it.

OR

With the help of a suitable example, explain how ionic compounds are formed. State any three general properties of ionic compounds.

25. (a) Draw a labelled diagram of sectional view of human heart.
(b) Describe double circulation in human beings. Why is it necessary ?

OR

- Draw a diagram of excretory system in human beings and label the following
(i) left kidney (ii) vena cava (iii) urinary bladder (iv) urethra
 - Write two major components of human urine.
26. (a) A coil of insulated copper wire is connected to a galvanometer. What will happen if a bar magnet is :
- pushed into the coil with its north pole entering first ?

- (ii) withdrawn from inside the coil ?
 (iii) held stationary inside the coil ?
- (b) Name the above phenomenon and mention the name of the scientist who discovered it. State the law that relates the direction of current in the coil with the direction of motion of the magnet.

OR

- (a) What is a solenoid ?
 (b) Draw the pattern of magnetic field produced around a current carrying solenoid. Compare this field to that of a bar magnet.
 (c) What happens to the magnetic field when the current through the solenoid is reversed ?
27. (i) Given below are the steps for extraction of copper from its ore. Write the reaction involved.
 (a) Roasting of copper (I) sulphide
 (b) Reduction of copper (I) oxide with copper (I) sulphide.
 (c) Electrolytic refining
- (ii) Draw a neat and well labelled diagram for electrolytic refining of copper

SECTION -B

28. A student tested the pH of distilled water and found that the colour of the pH paper changed to green. He checked the pH again after dissolving a pinch of common salt in it. The colour of the pH paper this time would be :

- (a) Green (b) Yellow
 (c) Red (d) Blue

29. On adding a few drops of universal indicator to three unknown colourless solutions (P), (Q) and (R) taken separately in three test tubes shown in the following diagrams, a student observed the changes in colour as green in (P), red in (Q) and violet in (R).

The decreasing order of pH of the solutions taken is :

- (a) $P > Q > R$
 (b) $R > P > Q$
 (c) $Q > P > R$
 (d) $R > Q > P$

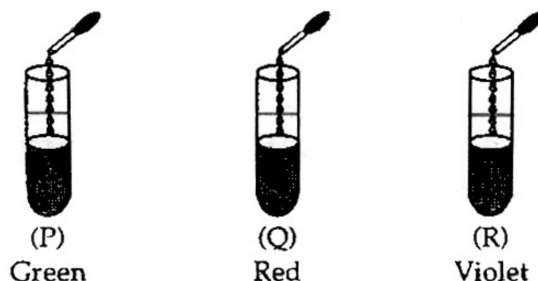

30. A solution of sodium carbonate is prepared by dissolving 1 g of it in 10 mL of distilled water. To this solution is added a strip of blue litmus paper 'A' and strip of red litmus paper 'B'. The colour of strips 'A' and 'B' will be :

- (a) blue in both cases
 (b) red in both cases
 (c) red in case of A and blue in case of B.
 (d) blue in case of A and red in case of B.

31. When crystals of FeSO_4 are strongly heated the residue obtained is

- (a) red in colour. (b) blue in colour.
 (c) green in colour. (d) colourless.

32. Iron filings were added to a solution of copper sulphate. After 10 minutes, it was observed that the blue colour of the solution has changed and a layer has deposited on iron filings. Which one of the following set of colours correspond to the colour of the solution and the colour of the coating respectively ?

- (a) Yellow and green.
- (b) Brown and blue.
- (c) Red and greenish blue.
- (d) Light green and reddish brown.

33. The current through a resistor connected in an electric circuit and the potential difference across its ends are shown in the diagrams.

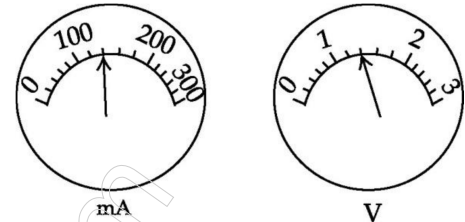

- The value of the resistance of the resistor is
- (a) 25Ω
 - (b) 20Ω
 - (c) 10Ω
 - (d) 15Ω

34. The symbol of a cell used in electric circuits is

- (a)
- (b)
- (c)
- (d)

35. In an experiment to study the dependence of current on potential difference across a resistor, the graph is plotted as shown in figure. The value of resistance of the resistor is:

- (a) 0.2Ω
- (b) 10Ω
- (c) 1.25Ω
- (d) 5Ω

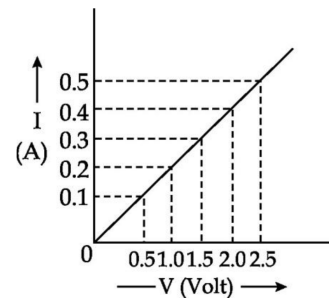

36. For the circuits A and B shown below the voltmeter readings would be :

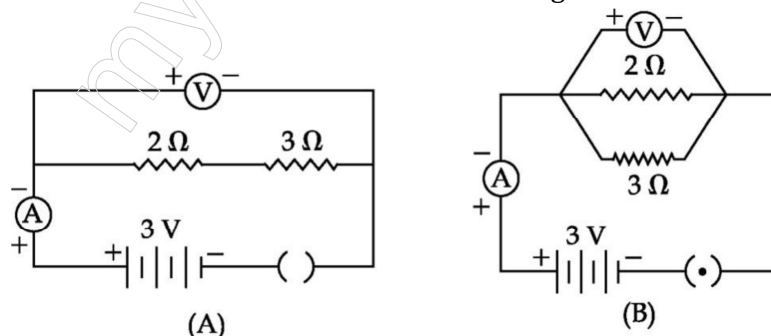

- (a) 0.6 V in circuit (A) and 2.5 V in circuit (B)
- (b) None of these
- (c) 3 V in both circuits
- (d) 0 V in circuit (A) and 3 V in circuit (B)

37. For the circuits shown in figure-1 and figure-2 the ammeter reading would be :

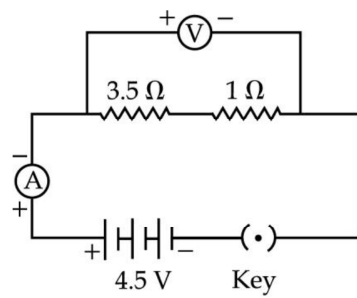

Fig. 1

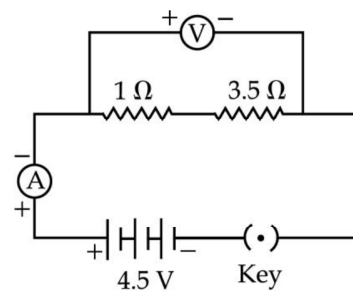
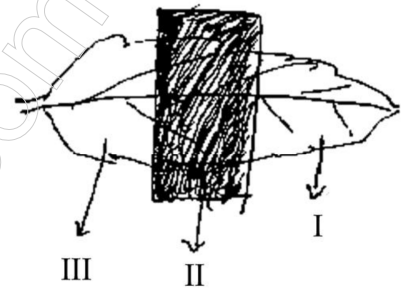

Fig. 2

- (a) 1.0A in figure 1 and 0.0A in figure 2
 (b) 0.0A in both
 (c) 1.0A in both
 (d) 1.0A in figure 1 and 1.0A in figure 2

38. Given is a sketch of a leaf of a potted plant which is partially covered with black paper and is to be used in the experiment to show that light is necessary for the process of photosynthesis. At the end of the experiment which one of the leaf parts labelled I, II and III will become blue black when dipped in iodine solution ?



- (a) I and II
 (b) II only
 (c) I and III
 (d) II and III

39. To determine that light is essential for photosynthesis, following are the steps, but not in sequence:
 (i) Pluck the leaf and do the starch test.
 (ii) Keep the selected plant in sunlight.
 (iii) Destarch the plant for 48 - 72 hours.
 (iv) Cover the leaf with black paper strip.

The correct sequence is

- (a) (iii), (i), (ii), (iv)
 (b) (iii), (ii), (iv), (i)
 (c) (iii), (iv), (ii), (i)
 (d) (i), (ii), (iv), (iii)

40. Which of the following cells possess well defined nucleus ?

- (a) (a) and (b)
 (b) (a) and (c)
 (c) (c) and (b)
 (d) (a), (b) and (c)

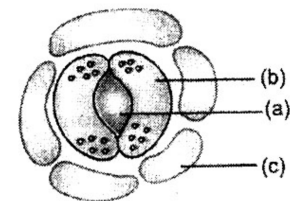

41. When we observe the slide of epidermal leaf peel we find that the inner walls of guard cells in contact with the stomatal pore are :
 (a) Very thick
 (b) Moderately thick
 (c) Moderately thin
 (d) Thin
42. Before setting up an experiment to show that seeds release CO₂ during respiration, the seeds should be :
 (a) dried completely.
 (b) boiled to make them soft.
 (c) soaked in vinegar.
 (d) kept moist till they germinate.

43. In the experimental setup shown in the figure, water is found to rise in the bent tube. The reason is that

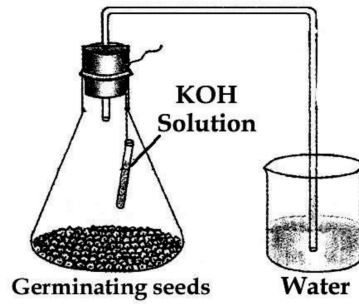

- (a) seeds use up oxygen in the flask.
(b) carbon dioxide is given out by germinating seeds.
(c) germinating seeds attract water from the beaker.
(d) seeds use oxygen and release CO₂ which is absorbed by potassium hydroxide due to which a partial vacuum is created in the flask.

SUMMATIVE ASSESSMENT – I
SCIENCE
Class – IX

Solution

Section - A

1. Pure water is bad conductor of electricity H_2SO_4 is added to make it a good conductor.
2. Mercury.
3. Commercially viable sites, are very less in number.
4. Current will be half of its former value.
5. Alloy is a homogenous mixture of two or more metals or a metal and a non metal.
Composition Brass - copper, zinc; Uses-nuts-bolts, utensils, decorative articles. Solder. Lead, tin; used in fuse wires.
6. Washing soda ($\text{Na}_2\text{CO}_3 \cdot 10\text{H}_2\text{O}$)
7. (a) X is CaO
 $\text{Ca} + \text{H}_2\text{O} \rightarrow \text{Ca}(\text{OH})_2$
(b) Copper from copper sulphate solution (Blue) is displaced by iron forming iron sulphate solution which is pale green in colour.
8. (i) $\text{BaCl}_2 + \text{H}_2\text{SO}_4 \rightarrow \text{BaSO}_4 + 2\text{HCl}$
(ii) $\text{Ca}(\text{OH})_2 + 2\text{HNO}_3 \rightarrow \text{Ca}(\text{NO}_3)_2 + 2\text{H}_2\text{O}$
(iii) $2\text{Pb}(\text{NO}_3)_2 \rightarrow 2\text{Pb} + 4\text{NO}_2 + \text{O}_2$
(iv) $\text{MnO}_2 + 4\text{HCl} \rightarrow \text{MnCl}_2 + 2\text{H}_2\text{O} + \text{Cl}_2$
9. Desert plants take up CO_2 at night and prepare an intermediate molecule. The intermediate molecule is acted upon by the energy absorbed by the chlorophyll during the day.
10. Due to sunlight water at the surface of the sea gets heated up while in the deeper regions water is relatively cold. This difference in temperature is utilized to produce electrical energy.
The warm surface water is used to boil a volatile liquid like ammonia. The vapours of the liquid are then used to run the turbine of generator and electricity is produced.
11. $H = I^2 RT$
 $= 25 \times 20 \times 30$
 $H = 15000 \text{ J}$

12. 1st observation is correct

Force on a current carrying conductor placed in a magnetic field is directly proportional to the strength of current

13. A larger current will flow through the circuit when thick wire is connected to it.

Since, $R = 1/A$

The resistance of thick wire will be lower as compared to thin wire. So a larger current will flow through the circuit with thick wire.

14. (a) Correct definition

(b) Photochemical decomposition

(c) Double displacement

15. (a) Evaporation of water from sea water and recrystallisation of the crude salt sample

(b) (i) 7

(ii) less than 7

16. (a) Calcium sulphate hemihydrate

(b) $\text{CaSO}_4 \cdot 2\text{H}_2\text{O}$

(c) $\text{CaSO}_4 \cdot \frac{1}{2} \text{H}_2\text{O} + 1\frac{1}{2} \text{H}_2\text{O} \rightarrow \text{CaSO}_4 \cdot 2\text{H}_2\text{O}$

17. Reflex Arc : Path followed by an impulse from a receptor organ to an effective organ.

Diagram of Reflex Arc :

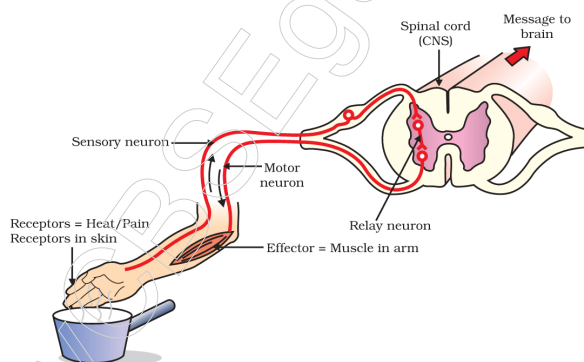

18. Upward and downward movement of shoot and root respectively of a plants away or towards earth during its growth is called geotropism.

Place a potted plant on its side in sunlight.

Observation : The shoot bends upwards (negative geotropism)

- The roots bend downwards (positive geotropism)

19. They do not produce much heat on burning and a lot of smoke is given out when they are burnt. The Technological inputs to improve the efficiency of these fuels :

(i) When wood is burnt in a limited supply of oxygen, water and volatile materials present in it get removed and charcoal is left behind as the residue. Charcoal burns without flames, is comparatively smokeless and has a higher heat generation efficiency.

(ii) Cow - dung, various plant materials like the residue after harvesting the crops, vegetable Waste and sewage are decomposed in the absence of oxygen to give bio-gas.

20. Two resistors of resistance R_1 and R_2 are connected in series. Let I be the current through the circuit. The current through each resistor is also I . The two resistors joined in series is replaced by an equivalent single resistor of resistance R such that the potential difference V across it, and the current I through the circuit remains same.

$$V = IR \quad V_1 = IR_1$$

$$V_2 = IR_2$$

$$IR = IR_1 + IR_2$$

$$IR = I(R_1 + R_2)$$

$$R = R_1 + R_2$$

21. (a) Electric fuse is a safety device which is used to safeguard electrical appliances.

- (b) This means that 60J of energy is used per second.

$$\text{Energy} = Pt = 60 \times 1 \text{ h} = 60 \text{ Wh} = 0.06 \text{ kWh}$$

22. Same voltage as that of the power line.

Overall resistance is reduced - current from the power supply is high.

If one electrical appliance stops working all other appliances keep working normally.

23. Sodium Carbonate Decahydrate ; $\text{Na}_2\text{CO}_3 \cdot 10\text{H}_2\text{O}$

Obtained by heating baking Soda and Recrystallization

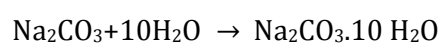

24. (i) Na -- 2, 8, 1

O --- 2, 6

Mg --- 2, 8, 2

11: Sodium

2,8,1

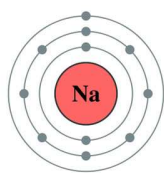

Na

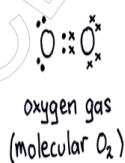

oxygen gas
(molecular O_2)

O_2

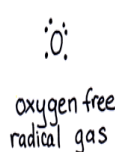

oxygen free
radical gas

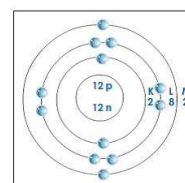

Mg

- (ii) Formation of MgO .



2,8,2 2,6

2,8

stable configuration.

- (iii) Mg^{2+} ions and

O^{2-} ions are present

OR

Ionic compound formed by transfer of electrons in outer most shell of the atom of a metal to 2 outermost shell of a non-metal so that both acquire a complete octet.

General properties for ionic compounds—

- (i) *Physical nature*: Ionic compounds are solids and are somewhat hard because of the strong force of attraction between the positive and negative ions. These compounds are generally brittle and break into pieces when pressure is applied.
- (ii) *Melting and Boiling points*: Ionic compounds have high melting and boiling points. This is because a considerable amount of energy is required to break the strong inter-ionic attraction.
- (iii) *Solubility*: Electrovalent compounds are generally soluble in water and insoluble in solvents such as kerosene, petrol, etc.

25. Double circulation refers to the flow of blood twice through the heart, during each cycle of transport through the body.

(i) Systemic circulation (ii) Pulmonary circulation

The deoxygenated blood is brought to the right atrium of the heart, by inferior vena cava and superior vena cava. From here, the blood moves into the right ventricle, this pumps it the lungs through pulmonary artery. The oxygenated blood is brought to the left atrium by pulmonary veins. From here, the blood moves into the left ventricle, this pumps it to all parts of the body through aorta. Double circulation is necessary because the oxygenated blood from lungs comes to the heart and deoxygenated blood from heart goes back to the lungs for purifying, i.e. for removing CO₂ from the blood.

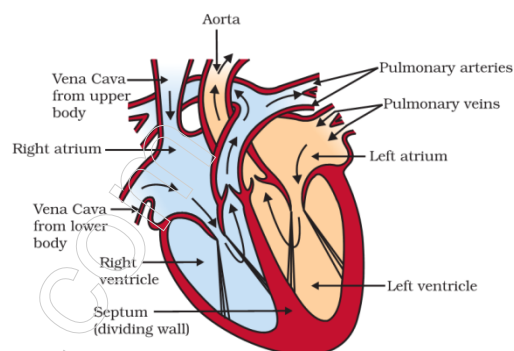

OR

(a) Human Excretory System

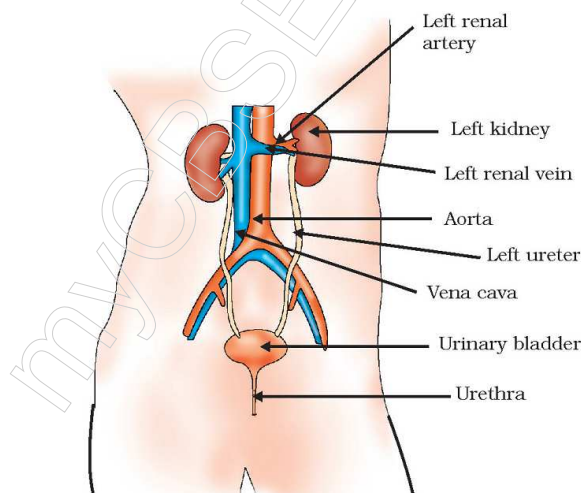

(b) Urea, uric acid.

26. (a) (i) A momentary deflection - indicates momentary current-direction of current in the coil - anticlockwise
(ii) Deflection in opposite direction - current of an opposite direction
(iii) No deflection - no current is produced in the coil
- (b) Electromagnetic Induction ; Faraday,
Fleming's right hand rule ; Stretch the thumb, forefinger and middle finger of right hand so that they are perpendicular to each other, as shown in . If the forefinger indicates the

direction of the magnetic field and the thumb shows the direction of motion of conductor, then the middle finger will show the direction of induced current.

OR

- (a) A coil of many circular turns of insulated copper wire wrapped closely in the shape of a cylinder is called solenoid
- (b) It is clear from the above pattern that the magnetic field of a current carrying solenoid resembles the field of a bar magnet
- (c) Magnetic field also reverses.

27. (i) (a) Roasting of sulphide ore $2\text{Cu}_2\text{S}(s) + 3\text{O}_2(g) \rightarrow 2\text{Cu}_2\text{O}(s) + 2\text{SO}_2(g)$
 (b) $2\text{Cu}_2\text{O} + \text{Cu}_2\text{S} \rightarrow 6\text{Cu}(s) + \text{SO}_2(g)$ This reaction is known as auto-reduction
 (c) Reaction for electrolytic refining
 At cathode : $\text{Cu}^{2+}(\text{aq}) + 2\text{e}^- \rightarrow \text{Cu}(s)$
 At anode : $\text{Cu}(s) \rightarrow \text{Cu}^{2+}(\text{aq}) + 2\text{e}^-$

(ii) Diagram for electrolytic refining of copper.

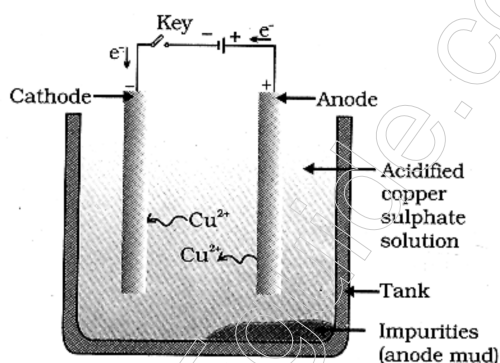

SECTION -B

- | | | | | | |
|--------|--------|--------|--------|--------|--------|
| 28.(a) | 29.(b) | 30.(a) | 31.(a) | 32.(d) | 33.(c) |
| 34.(b) | 35.(d) | 36.(d) | 37.(c) | 38.(c) | 39.(b) |
| 40.(c) | 41.(a) | 42.(d) | 43.(d) | | |