

DO NOT OPEN THIS TEST BOOKLET UNTIL YOU ARE ASKED TO DO SO

T.B.C. : B-FRF-M-DSA

Test Booklet Series

Serial No.

TEST BOOKLET
ELECTRONICS AND
TELECOMMUNICATION
ENGINEERING



Paper I

Time Allowed : Two Hours

Maximum Marks : 200

INSTRUCTIONS

1. IMMEDIATELY AFTER THE COMMENCEMENT OF THE EXAMINATION, YOU SHOULD CHECK THAT THIS TEST BOOKLET **DOES NOT** HAVE ANY UNPRINTED OR TORN OR MISSING PAGES OR ITEMS, ETC. IF SO, GET IT REPLACED BY A COMPLETE TEST BOOKLET.
2. PLEASE NOTE THAT IT IS THE CANDIDATE'S RESPONSIBILITY TO ENCODE AND FILL IN THE ROLL NUMBER AND TEST BOOKLET SERIES CODE A, B, C OR D CAREFULLY AND WITHOUT ANY OMISSION OR DISCREPANCY AT THE APPROPRIATE PLACES IN THE *OMR* ANSWER SHEET. ANY OMISSION/DISCREPANCY WILL RENDER THE ANSWER SHEET LIABLE FOR REJECTION.
3. You have to enter your Roll Number on the Test Booklet in the Box provided alongside. **DO NOT** write *anything else* on the Test Booklet.
4. This Test Booklet contains **120** items (questions). Each item comprises four responses (answers). You will select the response which you want to mark on the Answer Sheet. In case you feel that there is more than one correct response, mark the response which you consider the best. In any case, choose **ONLY ONE** response for each item.
5. You have to mark your responses **ONLY** on the separate Answer Sheet provided. See directions in the Answer Sheet.
6. All items carry equal marks.
7. Before you proceed to mark in the Answer Sheet the response to various items in the Test Booklet, you have to fill in some particulars in the Answer Sheet as per instructions sent to you with your Admission Certificate.
8. After you have completed filling in all your responses on the Answer Sheet and the examination has concluded, you should hand over to the Invigilator **only the Answer Sheet**. You are permitted to take away with you the Test Booklet.
9. Sheets for rough work are appended in the Test Booklet at the end.
10. **Penalty for wrong answers :**
THERE WILL BE PENALTY FOR WRONG ANSWERS MARKED BY A CANDIDATE.
 - (i) There are four alternatives for the answer to every question. For each question for which a wrong answer has been given by the candidate, **one-third (0.33)** of the marks assigned to that question will be deducted as penalty.
 - (ii) If a candidate gives more than one answer, it will be treated as **wrong answer** even if one of the given answers happens to be correct and there will be same penalty as above to that question.
 - (iii) If a question is left blank i.e. no answer is given by the candidate, there will be **no penalty** for that question.

DO NOT OPEN THIS TEST BOOKLET UNTIL YOU ARE ASKED TO DO SO

1. The coordination number and the atomic packing factor for Hexagonal Close Packed (HCP) and Face-Centred Cubic Crystal Structure are respectively
 - (a) 8 and 0.74
 - (b) 12 and 0.68
 - (c) 8 and 0.68
 - (d) 12 and 0.74

2. The resistivity of material is a function of temperature because
 - (a) electron density varies with temperature
 - (b) electron gas density varies with temperature
 - (c) amplitude of vibration of atom varies with temperature
 - (d) All of the above

3. Medium doping in Silicon and Germanium corresponds to impurity of the order of
 - (a) 1 part in 10^6
 - (b) 1 part in 10^5
 - (c) 1 part in 10^4
 - (d) 1 part in 10^8

4. An electric field is applied to a semiconductor. Let the number of charge carrier be n and the average drift speed be v . If the temperature is increased then
 - (a) both n and v will increase
 - (b) n will increase but v will decrease
 - (c) v will increase but n will decrease
 - (d) both n and v will decrease

5. In a piezoelectric crystal oscillator, if x represents the mass of the crystal, then the oscillation or tuning frequency is linearly proportional to
 - (a) the mass of the crystal
 - (b) the square root of the mass of the crystal
 - (c) the square of the mass of the crystal
 - (d) the inverse of the square root of the mass of the crystal

6. The temperature above which an antiferromagnetic material becomes paramagnetic is called
 - (a) Neel temperature
 - (b) Peak temperature
 - (c) Critical temperature
 - (d) Weiss temperature

7. The relative permeability is less than 1 in
 - (a) ferromagnetic materials
 - (b) diamagnetic materials
 - (c) paramagnetic materials
 - (d) ferrites

8. Which one of the following quantities can be measured with the help of the piezoelectric crystal ?
- Acceleration
 - Flow
 - Temperature
 - Velocity
9. As per Curie-Weiss law, the magnetic susceptibility of a material varies as
- T^{-2}
 - $1/T$
 - T
 - T^2
10. Ferrites have
- low copper loss
 - low eddy current loss
 - low resistivity
 - higher specific gravity than that of the iron
11. Two lamps each of 230 V and 60 W rating are connected in series across a single phase 230 V supply. The total power consumed by the two lamps would be
- 120 W
 - 60 W
 - 30 W
 - 15 W
12. Two charges are placed at a small distance apart. If a glass slab is placed between them, the force between the charges will
- not change
 - increase
 - decrease
 - reduce to zero
13. The total capacitance of two capacitors is 25 F when connected in parallel and 4 F when connected in series. The individual capacitances of the two capacitors are
- 1 F and 24 F
 - 3 F and 21 F
 - 5 F and 20 F
 - 10 F and 15 F
14. A coil having an inductance of 4 H and a resistance of 2Ω is connected across a 20 V dc source. The steady-state current (in amperes) through the coil is
- 5
 - 3.3
 - 10
 - 6.6
15. An electric motor is developing 10 kW at a speed of 900 rpm. The torque available at the shaft is
- 106 N-m
 - 66 N-m
 - 1600 N-m
 - 90 N-m

16. A heavily doped semiconductor has

- (a) a resistivity which decreases exponentially with temperature
- (b) a resistivity which rises almost linearly with temperature
- (c) a negative temperature coefficient of resistance
- (d) a positive temperature coefficient of resistance

17. A Zener diode has the following properties :

1. It is properly doped crystal diode with sharp breakdown
2. It is reverse biased
3. Its forward characteristics are just that of ordinary diode
4. Its reverse characteristics are like ordinary diode

- (a) 1, 2, 3 and 4
- (b) 1, 2 and 4 only
- (c) 1, 2 and 3 only
- (d) 3 and 4 only

18. A tunnel diode is a $p-n$ junction in which

- (a) n -region is degenerately doped
- (b) p -region is degenerately doped

- (c) either n or p -region is degenerately doped
- (d) both n and p -regions are degenerately doped

19. Which is the diode used for measuring light intensity ?

- (a) Junction diode
- (b) Varactor diode
- (c) Tunnel diode
- (d) Photo diode

20.

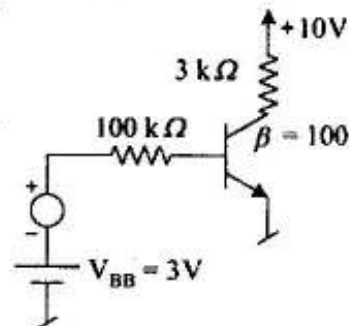

The trans-conductance g_m of the transistor used in the CE amplifier shown in the above circuit, operating at room temperature is

- (a) 92 mA/V
- (b) 46 mA/V
- (c) 184 mA/V
- (d) 25 mA/V

21. Which of the following are essentials of a transistor biasing circuit ?

1. Proper zero signal collector current flow
2. V_{CE} should not fall below 0.5 V for Germanium and 1 V for Silicon
3. Ensure stabilization of operating point
4. Loading to the source

- (a) 1, 2 and 3 only
(b) 1, 2 and 4 only
(c) 3 and 4 only
(d) 1, 2, 3 and 4

22. When a transistor is saturated,

- (a) the emitter potential is more than the base-collector potential
- (b) the collector potential is more than the base-emitter potential
- (c) the base potential is more than the emitter-collector potential
- (d) the base, emitter and collector are almost the same potential

23. If the α value of a transistor changes 0.5% from its nominal value of 0.9, the percentage change in β will be

- (a) 0%
(b) 2.5%
(c) 5%
(d) 7.5%

24. If an npn silicon transistor is operated at $V_{CE} = 5$ V and $I_C = 100$ μ A and has a current gain of 100 in the CE connection, then the input resistance of this circuit will be

- (a) 250 Ω
(b) 25 k Ω
(c) 250 k Ω
(d) 2500 k Ω

25. In a bipolar junction transistor an increase in magnitude of collector voltage increases the space-charge width at the output junction diode. This causes the effective base width to decrease. This effect is known as

- (a) Hall effect
(b) Early effect
(c) Miller effect
(d) Zener effect

26. Which type of protection is provided for SCR by connecting the snubber circuit across it ?

- (a) $\frac{dv}{dt}$ protection
(b) $\frac{di}{dt}$ protection
(c) Over-voltage protection
(d) Over-current protection

27. A capacitor of $100 \mu\text{F}$ is charged to 10 V through a resistance of $10 \text{ k}\Omega$. It would be fully charged in

- (a) 5 sec
- (b) 0.1 sec
- (c) 1.0 sec
- (d) 0.5 sec

28. Most of the linear ICs are based on two-transistor differential amplifiers because of

- (a) input voltage-dependent linear transfer characteristic
- (b) high voltage gain
- (c) high input resistance
- (d) high CMRR

29. When the photo resist coating (during IC fabrication) is exposed to ultraviolet light the photo resist becomes

- (a) oxidized
- (b) ionized
- (c) polymerized
- (d) brittle

30. For a sheet with resistivity ρ , width w , length l and thickness y , the resistance per square (sheet resistance) R_s is

- (a) $\frac{\rho}{y}$
- (b) ρy
- (c) $\frac{\rho l}{y}$
- (d) $\frac{\rho}{ly}$

31. An optical fibre has refractive index core

- (a) high and low refractive index cladding
- (b) low and high refractive index cladding
- (c) uniform surrounded by variable index cladding
- (d) variable with refractive index increases from low at the centre to high at the junction with cladding

32. The wavelength beyond which photoelectric emission cannot take place is called

- (a) long wavelength
- (b) optical wavelength
- (c) photoelectric wavelength
- (d) critical wavelength

33.

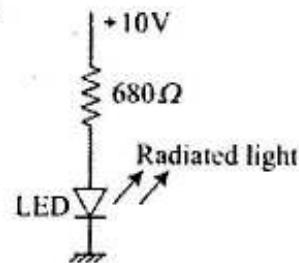

The Light Emitting Diode (LED), shown in the above figure has a voltage drop of 2 V . The current flowing through LED is

- (a) 11.8 mA
- (b) 0.0147 mA
- (c) 2.941 mA
- (d) 0.0176 mA

34. If a continuous time signal $x(t)$ can take on any value in the continuous interval $(-\infty, \infty)$, it is called

- (a) Deterministic signal
- (b) Random signal
- (c) Analog signal
- (d) Digital signal

35. The value of the integral

$$I = \int_1^2 (5t^2 + 1) \delta(t) dt \text{ is}$$

- (a) 0
- (b) 1
- (c) $\frac{42}{3}$
- (d) $\frac{125}{3}$

36. A continuous time system will be BIBO stable if all the Eigen values are

- (a) one
- (b) distinct and their real parts negative
- (c) negative
- (d) zero

37. The value of $\int_{-\infty}^{\infty} \sin t \delta\left(t - \frac{\pi}{4}\right) dt$ is

- (a) $\sqrt{2}$
- (b) $\frac{1}{\sqrt{3}}$
- (c) $\frac{1}{\sqrt{2}}$
- (d) $\sqrt{3}$

38. The forced response $y_f(n)$ of the differential equation

$$y(n) - 0.6y(n-1) = (0.4)^n, \quad n \geq 0$$

$$y(-1) = 10$$

- (a) $9(0.6)^n$
- (b) $-2(0.4)^n$
- (c) $9(0.4)^n$
- (d) $9(0.6)^n - 2(0.4)^n$

39. The ramp function can be obtained from the unit impulse at $t = 0$ by

- (a) differentiating unit impulse function once
- (b) differentiating unit impulse function twice
- (c) integrating unit impulse function once
- (d) integrating unit impulse function twice

40. Homogeneous solution of

$$y(n) - \frac{9}{16}y(n-2) = x(n-1) \text{ is}$$

- (a) $C_1\left(\frac{3}{4}\right)^n + C_2\left(-\frac{3}{4}\right)^n$
- (b) $C_1\left(-\frac{3}{4}\right)^{n-1} + C_2\left(\frac{3}{4}\right)^{n-1}$
- (c) $C_1\left(\frac{3}{4}\right)^n$
- (d) $C_1\left(-\frac{3}{4}\right)^n$

41. A source of (power/energy) feeds the input port of an amplifier and the output port is connected to a 'load'. The input impedance of the ideal amplifier should ideally be

- (a) zero
- (b) ∞
- (c) low
- (d) high

42.

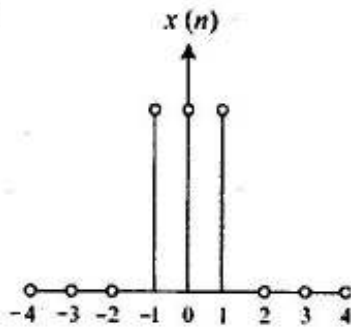

The signal $x(n)$ shown in the above figure is a

- (a) periodic discrete time signal
- (b) periodic signal
- (c) non-periodic signal
- (d) periodic discrete time signal consisting of 3 non-zero samples

43. Which of the following Dirichlets conditions are correct for convergence of Fourier transform of the function $x(t)$?

- 1. $x(t)$ is square integrable
- 2. $x(t)$ must be periodic
- 3. $x(t)$ should have finite number of maxima and minima within any finite interval
- 4. $x(t)$ should have finite number of discontinuities within any finite interval

- (a) 1, 2, 3 and 4
- (b) 1, 2 and 4 only
- (c) 1, 3 and 4 only
- (d) 2, 3 and 4 only

44. If $f(t)$ is a real and odd function, then its Fourier transform $F(\omega)$ will be

- (a) real and even function of ω
- (b) real and odd function of ω
- (c) imaginary and odd function of ω
- (d) imaginary function of ω

45. For certain sequences which are neither absolutely summable nor square summable, it is possible to have a Fourier Transform (FT) representation if we

- (a) take short time FT
- (b) evaluate FT only the real part of the sequence
- (c) allow DTFT to contain impulses
- (d) evaluate FT over a limited time span

46. A unit impulse function $\delta(t)$ is defined by

1. $\delta(t) = 0$ for all t except $t = 0$

2. $\int_{-\infty}^{\infty} \delta(t) dt = 1$

The Fourier transform $F(\omega)$ of $\delta(t)$ is

- (a) 1
- (b) $\frac{1}{\omega}$
- (c) 0
- (d) $\frac{1}{j\omega}$

47. The convolution $x(n) * \delta(n - n_0)$ is equal to

- (a) $x(n - n_0)$
- (b) $x(n + n_0)$
- (c) $x(n_0)$
- (d) $x(n)$

48. If the z -transform of

$x(n)$ is $x(z) = \frac{z(8z - 7)}{4z^2 - 7z + 3}$, then the

$\lim_{n \rightarrow \infty} x(n)$ is

- (a) 1
- (b) 2
- (c) ∞
- (d) 0

49. The final value theorem is

- (a) $\lim_{k \rightarrow \infty} x(k) = \lim_{z \rightarrow 1} (z-1)X^+(z)$
- (b) $\lim_{k \rightarrow \infty} x(k) = \lim_{z \rightarrow 1} X^+(z)$
- (c) $\lim_{k \rightarrow \infty} x(k) = \lim_{z \rightarrow 0} (z^{-1})X^+(z)$
- (d) $\lim_{k \rightarrow \infty} x(k) = \lim_{z \rightarrow 0} (z-1)^{-1}X^+(z^{-1})$

50. For the discrete signal $x[n] = a^n u[n]$ the z -transform is

- (a) $\frac{z}{z+a}$
- (b) $\frac{z-a}{z}$
- (c) $\frac{z}{a}$
- (d) $\frac{z}{z-a}$

51. If the power spectral density is $\frac{\eta}{2} \frac{W}{Hz}$, and the auto correlation function is defined by

$$R(\tau) = \frac{\eta}{2} \int_{-\infty}^{\infty} e^{j\omega\tau} df$$

The integral on the right represents the Fourier transform of

- (a) Delta function
- (b) Step function
- (c) Ramp function
- (d) Sinusoidal function

52. A battery is connected to a resistance causing a current of 0.5 A in the circuit. The current drops to 0.4 A when an additional resistance of 5 Ω is connected in series. The current will drop to 0.2 A when the resistance is further increased by

- (a) 10 Ω
- (b) 15 Ω
- (c) 25 Ω
- (d) 40 Ω

53.

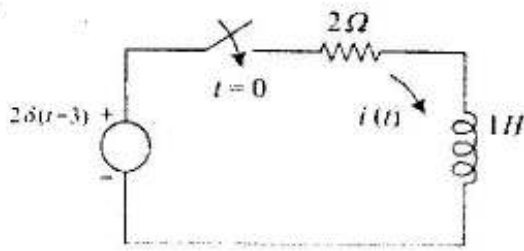

For the network shown above, the current $i(t)$ is

- (a) $2e^{-2(t-3)} u(t-3)$
- (b) $0.5e^{-2(t-3)} u(t)$
- (c) $2e^{-(t-3)} u(t-3)$
- (d) $2e^{-(t-3)} u(t)$

54.

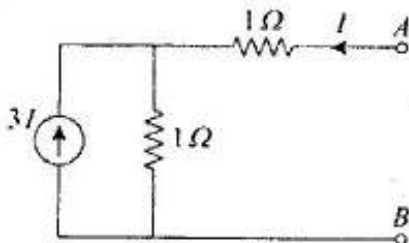

In the circuit shown above, the Thevenin resistance seen from the terminals AB is

- (a) 1Ω
- (b) 1.5Ω
- (c) 3Ω
- (d) 5Ω

55. A network N consists of resistors and independent voltage and current sources. Its value of the determinant based on the node analysis

1. cannot be negative
 2. cannot be zero
 3. is independent of the values of voltages and current sources
- (a) 1, 2 and 3
 - (b) 1 and 2 only
 - (c) 2 and 3 only
 - (d) 1 and 3 only

56.

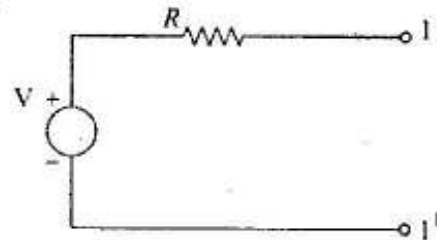

Thevenin equivalent circuit of a network N is shown above (at terminals $1 - 1'$).

To determine the value of R

1. all initial conditions are set to zero
 2. all independent sources are turned off
 3. all controlled sources are turned off
 4. small load connected to terminals $1 - 1'$ (outside network N) is removed
- (a) 1 and 2 only
 - (b) 1, 2 and 4
 - (c) 3 and 4 only
 - (d) 3 only

57. Consider the following data :

1. Input applied for $t < t_0$
2. Input applied for $t \geq t_0$
3. State of the network at $t = t_0$
4. State of the network at $t < t_0$

Which of these are needed for determining the response of a linear network for $t < t_0$?

- (a) 1, 3 and 4
 - (b) 2, 3 and 4
 - (c) 2 and 3 only
 - (d) 2 and 4 only
58. If a capacitor is energized by a symmetrical square wave current source, then the steady-state voltage across the capacitor will be a

- (a) square wave
- (b) triangular wave
- (c) step function
- (d) impulse function

59.

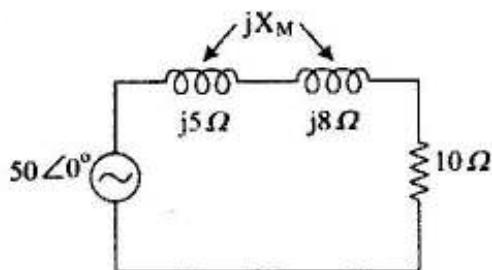

The power absorbed by the network excited by a $50 \angle 0^\circ$ sinusoidal source is 168 W. The value of the mutual inductive reactance jX_M should be

- (a) 13Ω
- (b) 10Ω
- (c) 6.3Ω
- (d) 3Ω

60.

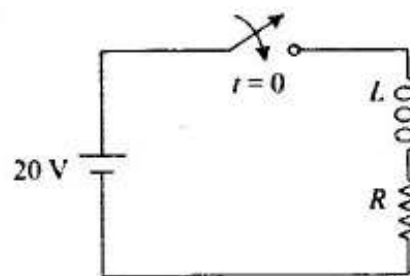

The circuit shown above ($L = 2 H$ and $R = 4 \Omega$) is switched across a D.C. power supply of 20 V. The current at time $t = 1$ sec is

- (a) 5 A
- (b) 4.32 A
- (c) 2 A
- (d) 0.5 A

61.

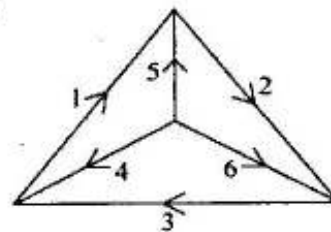

For the oriented graph as given above, taking 4, 5, 6 as tree branches the tie set matrix is

- (a)
$$\begin{bmatrix} -1 & 0 & 0 & -1 & 1 & 0 \\ 0 & -1 & 0 & 0 & -1 & 1 \\ 0 & 0 & -1 & 1 & 0 & -1 \end{bmatrix}$$
- (b)
$$\begin{bmatrix} 1 & 0 & 0 & 1 & -1 & 0 \\ 0 & 1 & 0 & 0 & 1 & -1 \\ 0 & 0 & 1 & -1 & 0 & 1 \end{bmatrix}$$
- (c)
$$\begin{bmatrix} 1 & -1 & 0 & -1 & 1 & 0 \\ 1 & 0 & 0 & 0 & -1 & 1 \\ 0 & 0 & 1 & 1 & 0 & -1 \end{bmatrix}$$
- (d)
$$\begin{bmatrix} -1 & 0 & 0 & -1 & 0 & 0 \\ 0 & -1 & 0 & 0 & 0 & 1 \\ 0 & 0 & 0 & 1 & 0 & -1 \end{bmatrix}$$

62. The number of branches in a network is b , the number of nodes is n and number of dependent loop is l . The number of independent current equations will be

- (a) $n - l - 1$
- (b) $b - l$
- (c) $b - n$
- (d) $n - 1$

63. Two two-port networks are connected in cascade. The combination is to be represented as a single two-port network. The parameters are obtained by multiplying the individual

- (a) h -parameter matrix
- (b) $ABCD$ parameter matrix
- (c) Y -parameter matrix
- (d) Z -parameter matrix

64.

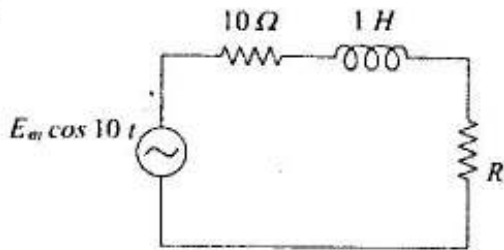

In the above circuit, the value of the load resistance R to absorb the maximum power is

- (a) 14.14Ω
- (b) 10Ω
- (c) 200Ω
- (d) 28.28Ω

65.

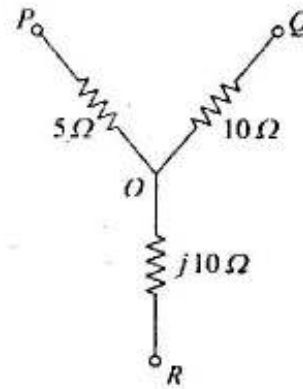

In the delta equivalent of the above star connected circuit, Z_{QR} is equal to

- (a) 40Ω
- (b) $(20 + j10) \Omega$
- (c) $(5 + j\frac{10}{3}) \Omega$
- (d) $(10 + j30) \Omega$

66. In the following statements, choose the correct combination(s) :

1. If $z_{11} = z_{22}$ and $|h| = 1$ the network is symmetric
2. If $h_{11} = h_{12}$ the network is symmetric
3. If $h_{12} = -h_{21}$ the network is reciprocal
4. If $A^2 - BC = 0$ the network is reciprocal

- (a) 1 and 3
- (b) 3 and 4
- (c) 1 and 4
- (d) 2 and 3

67. The transmission parameters in inverse hybrid (g) parameter form are expressed in terms of the

- (a) current of input port 1 and voltage of the output port 2 and which are expressed in terms of the input voltage and output current
- (b) input voltage and current of the input port 1 and which are expressed in terms of the output voltage and current of the output port 2
- (c) input voltage and output currents of port 1 and port 2 respectively and which are expressed in terms of the input current and output voltage of port 1 and port 2 respectively
- (d) None of the above

68. Two identical 2-port networks N_A and N_B are connected in cascade to form a composite network N . The transmission parameters of N are given by the matrix

$$\begin{bmatrix} 7 & 12 \\ 4 & 7 \end{bmatrix}$$

The transmission matrix for the individual network is

- (a) $\begin{bmatrix} 3.5 & 6 \\ 2 & 3.5 \end{bmatrix}$
- (b) $\begin{bmatrix} 14 & 24 \\ 8 & 14 \end{bmatrix}$
- (c) $\begin{bmatrix} 2 & 3 \\ 1 & 2 \end{bmatrix}$
- (d) $\begin{bmatrix} 3 & 2 \\ 2 & 1 \end{bmatrix}$

69.

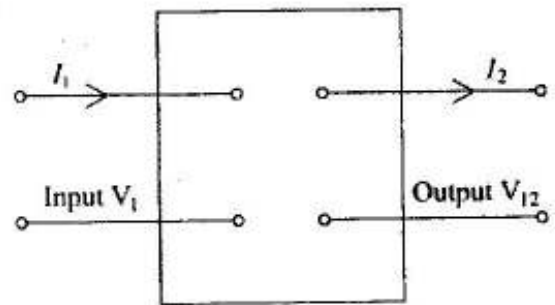

The condition of symmetry in $ABCD$ parameters in the system shown above will be

- (a) $A = D$
- (b) $B = \frac{1}{A}$
- (c) $A = \frac{1}{B}$
- (d) $B = D$

70. Which of the following statements are **not** true for the driving point functions of a lossless network ?

1. They are the ratio of odd to even or even to odd polynomials.
2. They do not satisfy the separation property.
3. They have either a pole or a zero at the origin and infinity.
4. Their degrees of the numerator and denominator polynomials differ by 2 and only 2.

- (a) 1 and 2
- (b) 1 and 3
- (c) 2 and 3
- (d) 2 and 4

71. For a driving point function, with n = degree of numerator polynomial and m = degree of denominator polynomial, the relationship connecting n and m is

- (a) $|n - m| \leq 1$
- (b) $|n - m| = 0$
- (c) $(n - m) < -1$
- (d) $n - m > 1$

72.

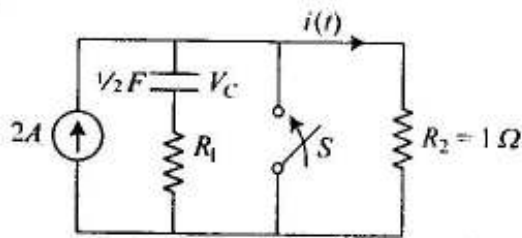

After closing the switch S at $t = 0$, the current $i(t)$ at any instant t in the above network is

- (a) $10 + 10e^{100t}$
- (b) $10 - 10e^{100t}$
- (c) $10 + 10e^{-100t}$
- (d) $10 - 10e^{-100t}$

73. If $Z(s) = \frac{s^3 + 10s^2 + 25s + 18}{(s+1)(s+3)(s+5)}$, it is

- (a) an RC driving-point impedance
- (b) an RL driving-point impedance
- (c) an LC driving-point impedance
- (d) None of the above

74.

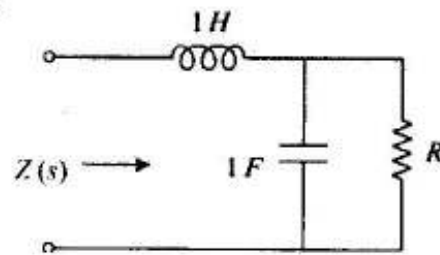

The driving-point impedance $Z(s)$ of the circuit shown in the above figure is

- (a) $\frac{s^2 + Rs}{1 + Rs}$
- (b) $\frac{Rs^2 + s + R}{Rs + 1}$
- (c) $\frac{s^2(R+1) + 3}{1 + Rs}$
- (d) $\frac{1}{(1 + Rs)^2}$

75. Which of the following are electromagnetic in nature ?

1. Alpha rays
2. X-rays
3. Gamma rays
4. Cathode rays

- (a) 1 and 2
- (b) 2 and 3
- (c) 3 and 4
- (d) 1 and 4

76. The ratio of the charges stored by two metallic spheres raised to the same potential is 6. The ratio of the surface area of the sphere is

- (a) 6
- (b) $\frac{1}{6}$
- (c) 36
- (d) $\frac{1}{\sqrt{6}}$

77. The field strength of a plane wave is 2 V/m. The strength of the magnetic field (H) in free space is

- (a) 5.2 mA/m
- (b) 2.25 mA/m
- (c) 250 mA/m
- (d) 520 mA/m

78. A coil of inductance 2 H and resistance 1 Ω is connected to a 10 V battery with negligible internal resistance. The amount of energy stored in the magnetic field is

- (a) 8 J
- (b) 50 J
- (c) 25 J
- (d) 100 J

79. Electric displacement current density D at any point on a spherical surface of radius r centred at the isolated charge q is

- (a) $\frac{q^2}{r^2}$
- (b) $\frac{q}{r^2}$
- (c) $\frac{q}{4\pi r^2}$
- (d) $\frac{q}{4\pi^2 r^2}$

80. Consider a uniform sphere of charge density ρ_0 and radius b centred at the origin. The electric field at a radial distance r ($r < b$), according to Gauss's law, is

- (a) $\frac{\gamma\rho_0}{3\epsilon}$
- (b) $\frac{\rho_0}{4\pi\epsilon r^2}$
- (c) $\frac{b^3\rho_0}{3\epsilon r^2}$
- (d) $\frac{\rho_0}{\gamma}$

where ϵ is the permittivity.

81. At a point (x, y, z) potential is given by $A(x^2 + y^2 + z^2)$. The potential difference between points $P(1, 0, 2)$ and $Q(1, 1, 2)$ is

- (a) 8 V
- (b) 8 A V
- (c) 9 A V
- (d) 9 V

82. The intrinsic impedance η of a conducting medium for which $\sigma = 58 \text{ Ms/m}$, $\mu_r = 1$ at a frequency of 100 MHz is

- (a) $2.14 \times 10^5 \angle 45^\circ \Omega$
- (b) $1.84 \times 10^{-3} \angle 45^\circ \Omega$
- (c) $3.69 \times 10^{-3} \angle 45^\circ \Omega$
- (d) $3.69 \times 10^{-3} \angle -45^\circ \Omega$

83. A conducting plane at $z = 0$ has a voltage of 100 V on it. V_1 and V_2 are two solutions, with $V_1 = 5z + 100$ and $V_2 = 100$; which satisfy Laplace equation as well as the boundary condition $V = 100$ at $z = 0$. Which of the following is the most correct option ?

- (a) Both V_1 and V_2 are correct and solution is not unique
- (b) Unique solution cannot be found
- (c) Only V_1 is the correct solution
- (d) The given plane does not serve as a proper boundary as the reference is not given

84. If $E = E_m \sin(\omega t - \beta_2 z) \bar{a}_y$ is free space, then B is given by

- (a) $\frac{-E_m \beta}{\omega} \sin(\omega t - \beta_2 z) \bar{a}_z$
- (b) $\frac{-E_m \beta}{\omega} \cos(\omega t - \beta_2 z) \bar{a}_x$

(c) $\frac{E_m \beta}{\omega} \sin(\omega t - \beta_2 z) \bar{a}_y$

(d) $\frac{E_m \beta}{\omega} \cos(\omega t - \beta_2 z) \bar{a}_y$

85. A uniform plane wave with an intensity of electric field 1 V/m is travelling in free space. The magnitude of associated magnetic field is

- (a) 2.65 mA/m
- (b) 2.65 A/m
- (c) 2.65 $\mu\text{A/m}$
- (d) 26.5 A/m

86. A reflectometer consists of

- (a) two directional couplers
- (b) one directional coupler and an isolator
- (c) one directional coupler and a circulator
- (d) two directional couplers and a circulator

87. A transmission line, has a characteristic impedance (Z_0) of 600Ω . Its length is 500 m. If the line is cut into half what will be the Z_0 for each half ?

- (a) $\frac{Z_0}{4}$
- (b) $\frac{Z_0}{2}$
- (c) Z_0
- (d) $2Z_0$

88. A plain wave is travelling in the positive X-direction in a lossless unbounded medium having permeability the same as the free space and a permittivity 9 times that of the free space, the phase velocity of the wave will be
- 3×10^8 m/s
 - 10^8 m/s
 - $\frac{1}{3} \times 10^8$ m/s
 - $\sqrt{3} \times 10^8$ m/s
89. In a semiconductor strain gauge, the change in resistance on application of strain is mainly due to change in
- length of the wire
 - diameter of the wire
 - resistivity of the material of the wire
 - both the length and diameter of the wire
90. In an LVDT, the two secondary windings are connected in differential mode to obtain
- higher output voltage
 - a reduction in output impedance
 - an increase in input impedance
 - the null for particular position of core
91. For an antenna, Radiation Intensity is defined as
- the time-averaged radiated power per unit solid angle
 - the peak radiated power per unit solid angle
 - the peak radiated power per unit area
 - the time-averaged radiated power per unit area
92. The resistances of two coils of a watt-meter are 0.0Ω and 100Ω respectively and both are non-inductive. The current through a resistance load is 20 A and the voltage across it is 30 V. In one of the two ways of connecting the voltage coil, the error in the reading would be
- 0.1% too high
 - 0.2% too high
 - 0.15% too high
 - zero
93. A 0-150 V voltmeter has a guaranteed accuracy of 1% full-scale reading. The voltage measured by this instrument is 83 V. The limiting error in per cent is
- 1.81%
 - 0.18%
 - 5.53%
 - 0.553%

94. The strain gauge should have

1. High gauge factor
2. Low resistance temperature coefficient
3. High resistance

Which of the above statements are correct ?

- (a) 1 and 2 only
- (b) 1 and 3 only
- (c) 2 and 3 only
- (d) 1, 2 and 3

95. The secondary of a CT is never left open-circuited because

1. The heat dissipation in the core will be very large
2. The core will be saturated and get permanently magnetized rendering it useless
3. Dangerously high emf will be induced in the secondary

Which of the above statements are correct ?

- (a) 1 and 2 only
- (b) 1 and 3 only
- (c) 1, 2 and 3
- (d) 2 and 3 only

96. A resistance strain gauge with gauge factor of 3 is subjected to a stress of 3000 kg/cm when fastened to a steel rod. The modulus of elasticity of steel is 2.1×10^6 kg/cm². The percentage change in resistance of the strain gauge element is

- (a) 0.1428%
- (b) 24.84%
- (c) 0.4284%
- (d) 4.3%

97. Two 100 V F.S.D. PMMC type dc voltmeters having figure of merit of 10 k Ω /V and 20 k Ω /V are connected in series. The series combination can be used to measure a maximum dc voltage of

- (a) 200 V
- (b) 175 V
- (c) 150 V
- (d) 125 V

98. The true rms responding voltmeter senses

- (a) the rms value divided by the average value of voltage
- (b) the square of the rms value of voltage
- (c) the actual rms value of voltage
- (d) the rms value divided by the peak value of voltage

99. A $4\frac{1}{2}$ digit voltmeter is used for measurements. It would display the voltage value 0.3861 on a 10 V range as
- 0.3861
 - 0.386
 - 0.38
 - 0.38610
100. What is the dynamic range of a spectrum analyzer with a third order intercept point of +25 dBm, and a noise level of (-) 85 dBm.
- 0.73 dB
 - 7.3 dB
 - 73 dB
 - 730 dB
101. The bandwidth of a digitally recorded signal primarily depends upon
- the physical properties of the system components processing the signal
 - the frequency at which the signal is sampled
 - the frequency of the clock signal that is used to encode binary values responding the signal
 - the frequency of the noise affecting signal quality
102. A 10-bit A/D converter is used to digitize an analog signal in the 0-5 V range. The maximum peak-to-peak ripple voltage that can be allowed in the dc supply voltage is nearly
- 100 mV
 - 50 mV
 - 25 mV
 - 5 mV
103. The wire in a metallic strain gauge is 0.1 m long and has an initial resistance of 120 ohm. On application of an external force, the wire length increases by 0.1 mm and the resistance increases by 0.21 ohm. The gauge factor of the strain gauge will be
- 3.00
 - 2.00
 - 1.75
 - 2.85
104. An LVDT has the following specifications :
- Input = 6.3 V,
Output = 5.2 V,
range ± 1.25 cm.
- Then the output voltages produced due to core movement from +1.1 cm to - 0.4 cm will be respectively
- +4.576 V and -1.664 V
 - +2.288 V and -0.832 V
 - +4.0 V and -1.0 V
 - +2.0 V and -1.0 V
105. A temperature sensitive transducer is subjected to a sudden temperature change. It takes 10 sec for the transducer to reach steady-state. The time taken by the transducer to read half of the temperature difference will be nearly
- 1.38 sec
 - 5.00 sec
 - 8.62 sec
 - 10 sec

106. A 1 m length wire has a resistance of 150Ω . When it is subjected to strain, its length becomes 1.01 m. The measurement is conducted by a strain gauge whose gauge factor is 2. The change in resistance of the wire is

- (a) 0.5Ω
- (b) 1.0Ω
- (c) 2.0Ω
- (d) 3.0Ω

107. While measuring the voltage developed by a thermocouple, it is found that there is always an offset voltage. This is due to

- (a) a voltage across a thermocouple even at very low temperature
- (b) some photoelectric voltage across the junction due to ambient light
- (c) a barrier potential across the junction
- (d) an additional thermocouple is formed due to the connecting wires and one of the metals

108. An LVDT (linear variable differential transformer) produces an output of 24 V rms for a displacement of 25×10^{-3} cm. This voltage is measured with a 5 V full-scale voltmeter with 100 major divisions, each major division readable to 0.2 divisions. The resolution of the voltmeter is

- (a) 0.125 mm
- (b) 31.25 mm
- (c) 1.25 mm
- (d) 3.125 mm

Directions :

Each of the next Twelve (12) items consists of two statements, one labelled as the 'Statement (I)' and the other as 'Statement (II)'. You are to examine these two statements carefully and select the answers to these items using the codes given below :

Codes :

- (a) Both Statement (I) and Statement (II) are individually true and Statement (II) is the correct explanation of Statement (I)
- (b) Both Statement (I) and Statement (II) are individually true but Statement (II) is *NOT* the correct explanation of Statement (I)
- (c) Statement (I) is true but Statement (II) is false
- (d) Statement (I) is false but Statement (II) is true

109. Statement (I) : Centre tap transformer is essential for a centre-tapped rectifier.

Statement (II) : In half wave rectification minimum two diodes are required.

110. Statement (I) : Power factor is a measure of the power flow in the insulator and should be low.

Statement (II) : It varies with the temperature and usually increases with the rise in temperature of the insulation.

111. Statement (I) : An SCR has a current-controlled negative resistance characteristic.

Statement (II) : For a given current the voltage can be determined while for a given voltage current cannot be determined.

112. Statement (I) : JFET is operated in depletion mode only.

Statement (II) : The input resistance of a MOSFET is several orders of magnitude greater than that of a JFET.

113. Statement (I) : Zero state response is usually referred as particular solution of the filter.

Statement (II) : Particular solution depends on only the input but not on the initial conditions.

114. Statement (I) : Zero input response is the natural response with zero initial conditions.

Statement (II) : Zero state response is the response with given input with zero initial conditions.

115. Statement (I) : Aliasing occurs when the sampling frequency is less than twice the maximum frequency in the signal.

Statement (II) : Aliasing is a reversible process.

116. Statement (I) : Sampling in one domain makes the signal to be periodic in the other domain.

Statement (II) : Multiplication in one domain is the convolution in the other domain.

117. Statement (I) : In an experiment having systematic error, increasing the sample size improves precision.

Statement (II) : Removing the systematic error improves accuracy.

118. Statement (I) : During measurement ammeter is connected in series as it has low resistance and small voltage drop.

Statement (II) : During measurement voltmeter is connected in parallel as it has high resistance and draws small current from the circuit.

119. Statement (I) : An instrumentation amplifier must have well-matched components.

Statement (II) : To be able to faithfully amplify differential signals, an instrumentation amplifier needs excellent common mode rejection ratio.

120. Statement (I) : A photodiode is an example of a photoconductive sensor.

Statement (II) : A photodiode can be used as either a photoconductive or a photoresistive sensor.

SPACE FOR ROUGH WORK

SPACE FOR ROUGH WORK

SPACE FOR ROUGH WORK