

**JEE (ADVANCED) 2019 PAPER 1**  
**PART-I PHYSICS**

**SECTION 1 (Maximum Marks: 12)**

- This section contains **FOUR (04)** questions.
- Each question has **FOUR** options. **ONLY ONE** of these four options is the correct answer.
- For each question, choose the option corresponding to the correct answer.
- Answer to each question will be evaluated according to the following marking scheme:  
*Full Marks* : +3 If **ONLY** the correct option is chosen;  
*Zero Marks* : 0 If none of the options is chosen (i.e. the question is unanswered);  
*Negative Marks* : -1 In all other cases.

- Q.1 Consider a spherical gaseous cloud of mass density  $\rho(r)$  in free space where  $r$  is the radial distance from its center. The gaseous cloud is made of particles of equal mass  $m$  moving in circular orbits about the common center with the same kinetic energy  $K$ . The force acting on the particles is their mutual gravitational force. If  $\rho(r)$  is constant in time, the particle number density  $n(r) = \rho(r)/m$  is  
 [G is universal gravitational constant]

(A)  $\frac{K}{2\pi r^2 m^2 G}$

(B)  $\frac{K}{\pi r^2 m^2 G}$

(C)  $\frac{3K}{\pi r^2 m^2 G}$

(D)  $\frac{K}{6\pi r^2 m^2 G}$

- Q.2 A thin spherical insulating shell of radius  $R$  carries a uniformly distributed charge such that the potential at its surface is  $V_0$ . A hole with a small area  $\alpha 4\pi R^2$  ( $\alpha \ll 1$ ) is made on the shell without affecting the rest of the shell. Which one of the following statements is correct?

(A) The potential at the center of the shell is reduced by  $2\alpha V_0$

(B) The magnitude of electric field at the center of the shell is reduced by  $\frac{\alpha V_0}{2R}$

(C) The ratio of the potential at the center of the shell to that of the point at  $\frac{1}{2}R$  from center towards the hole will be  $\frac{1-\alpha}{1-2\alpha}$

(D) The magnitude of electric field at a point, located on a line passing through the hole and shell's center, on a distance  $2R$  from the center of the spherical shell will be reduced by  $\frac{\alpha V_0}{2R}$

- Q.3 A current carrying wire heats a metal rod. The wire provides a constant power ( $P$ ) to the rod. The metal rod is enclosed in an insulated container. It is observed that the temperature ( $T$ ) in the metal rod changes with time ( $t$ ) as

$$T(t) = T_0(1 + \beta t^{\frac{1}{4}}),$$

where  $\beta$  is a constant with appropriate dimension while  $T_0$  is a constant with dimension of temperature. The heat capacity of the metal is,

(A)  $\frac{4P(T(t)-T_0)^3}{\beta^4 T_0^4}$       (B)  $\frac{4P(T(t)-T_0)^4}{\beta^4 T_0^5}$       (C)  $\frac{4P(T(t)-T_0)^2}{\beta^4 T_0^3}$       (D)  $\frac{4P(T(t)-T_0)}{\beta^4 T_0^2}$

- Q.4 In a radioactive sample,  ${}^{40}_{19}\text{K}$  nuclei either decay into stable  ${}^{40}_{20}\text{Ca}$  nuclei with decay constant  $4.5 \times 10^{-10}$  per year or into stable  ${}^{40}_{18}\text{Ar}$  nuclei with decay constant  $0.5 \times 10^{-10}$  per year. Given that in this sample all the stable  ${}^{40}_{20}\text{Ca}$  and  ${}^{40}_{18}\text{Ar}$  nuclei are produced by the  ${}^{40}_{19}\text{K}$  nuclei only. In time  $t \times 10^9$  years, if the ratio of the sum of stable  ${}^{40}_{20}\text{Ca}$  and  ${}^{40}_{18}\text{Ar}$  nuclei to the radioactive  ${}^{40}_{19}\text{K}$  nuclei is 99, the value of  $t$  will be, [Given:  $\ln 10 = 2.3$ ]

(A) 1.15      (B) 9.2      (C) 2.3      (D) 4.6

**SECTION 2 (Maximum Marks: 32)**

- This section contains **EIGHT (08)** questions.
- Each question has **FOUR** options. **ONE OR MORE THAN ONE** of these four option(s) is(are) correct answer(s).
- For each question, choose the option(s) corresponding to (all) the correct answer(s).
- Answer to each question will be evaluated according to the following marking scheme:
  - Full Marks : +4 If only (all) the correct option(s) is(are) chosen;
  - Partial Marks : +3 If all the four options are correct but **ONLY** three options are chosen;
  - Partial Marks : +2 If three or more options are correct but **ONLY** two options are chosen and both of which are correct;
  - Partial Marks : +1 If two or more options are correct but **ONLY** one option is chosen and it is a correct option;
  - Zero Marks : 0 If none of the options is chosen (i.e. the question is unanswered);
  - Negative Marks : -1 In all other cases.
- For example, in a question, if (A), (B) and (D) are the **ONLY** three options corresponding to correct answers, then
  - choosing **ONLY** (A), (B) and (D) will get +4 marks;
  - choosing **ONLY** (A) and (B) will get +2 marks;
  - choosing **ONLY** (A) and (D) will get +2 marks;
  - choosing **ONLY** (B) and (D) will get +2 marks;
  - choosing **ONLY** (A) will get +1 mark;
  - choosing **ONLY** (B) will get +1 mark;
  - choosing **ONLY** (D) will get +1 mark;
  - choosing no option (i.e. the question is unanswered) will get 0 marks; and
  - choosing any other combination of options will get -1 mark.

- Q.5 A cylindrical capillary tube of 0.2 mm radius is made by joining two capillaries T1 and T2 of different materials having water contact angles of  $0^\circ$  and  $60^\circ$ , respectively. The capillary tube is dipped vertically in water in two different configurations, case I and II as shown in figure. Which of the following option(s) is(are) correct?  
[Surface tension of water = 0.075 N/m, density of water =  $1000 \text{ kg/m}^3$ , take  $g = 10 \text{ m/s}^2$ ]

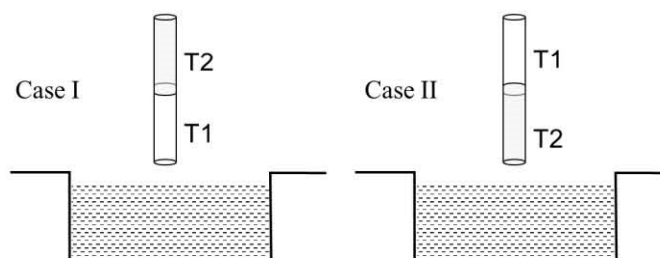

- (A) The correction in the height of water column raised in the tube, due to weight of water contained in the meniscus, will be different for both cases.
- (B) For case II, if the capillary joint is 5 cm above the water surface, the height of water column raised in the tube will be 3.75 cm. (Neglect the weight of the water in the meniscus)
- (C) For case I, if the joint is kept at 8 cm above the water surface, the height of water column in the tube will be 7.5 cm. (Neglect the weight of the water in the meniscus)
- (D) For case I, if the capillary joint is 5 cm above the water surface, the height of water column raised in the tube will be more than 8.75 cm. (Neglect the weight of the water in the meniscus)

- Q.6 A conducting wire of parabolic shape, initially  $y = x^2$ , is moving with velocity  $\vec{V} = V_0 \hat{i}$  in a non-uniform magnetic field  $\vec{B} = B_0 \left( 1 + \left( \frac{y}{L} \right)^\beta \right) \hat{k}$ , as shown in figure. If  $V_0$ ,  $B_0$ ,  $L$  and  $\beta$  are positive constants and  $\Delta\phi$  is the potential difference developed between the ends of the wire, then the correct statement(s) is/are:

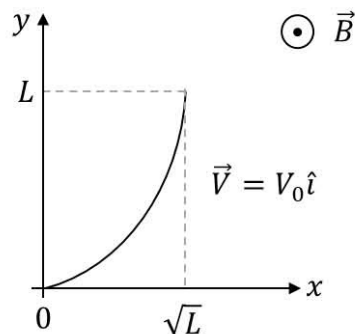

- (A)  $|\Delta\phi| = \frac{1}{2} B_0 V_0 L$  for  $\beta = 0$
- (B)  $|\Delta\phi| = \frac{4}{3} B_0 V_0 L$  for  $\beta = 2$
- (C)  $|\Delta\phi|$  remains the same if the parabolic wire is replaced by a straight wire,  $y = x$  initially, of length  $\sqrt{2} L$
- (D)  $|\Delta\phi|$  is proportional to the length of the wire projected on the  $y$ -axis.

- Q.7 In the circuit shown, initially there is no charge on capacitors and keys  $S_1$  and  $S_2$  are open. The values of the capacitors are  $C_1 = 10 \mu\text{F}$ ,  $C_2 = 30 \mu\text{F}$  and  $C_3 = C_4 = 80 \mu\text{F}$ .

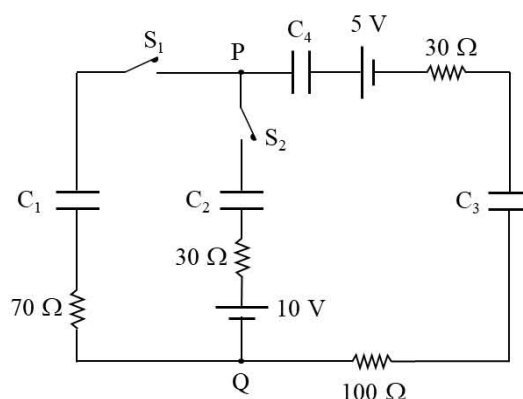

Which of the statement(s) is/are correct?

- (A) At time  $t = 0$ , the key  $S_1$  is closed, the instantaneous current in the closed circuit will be 25 mA.
- (B) If key  $S_1$  is kept closed for long time such that capacitors are fully charged, the voltage across the capacitor  $C_1$  will be 4 V.
- (C) The key  $S_1$  is kept closed for long time such that capacitors are fully charged. Now key  $S_2$  is closed, at this time, the instantaneous current across  $30 \Omega$  resistor (between points P and Q) will be 0.2 A (round off to 1<sup>st</sup> decimal place).
- (D) If key  $S_1$  is kept closed for long time such that capacitors are fully charged, the voltage difference between points P and Q will be 10 V.
- Q.8 A charged shell of radius  $R$  carries a total charge  $Q$ . Given  $\Phi$  as the flux of electric field through a closed cylindrical surface of height  $h$ , radius  $r$  and with its center same as that of the shell. Here, center of the cylinder is a point on the axis of the cylinder which is equidistant from its top and bottom surfaces. Which of the following option(s) is/are correct?  
 $[\epsilon_0$  is the permittivity of free space]

- (A) If  $h > 2R$  and  $r > R$  then  $\Phi = Q/\epsilon_0$
- (B) If  $h < 8R/5$  and  $r = 3R/5$  then  $\Phi = 0$
- (C) If  $h > 2R$  and  $r = 3R/5$  then  $\Phi = Q/5\epsilon_0$
- (D) If  $h > 2R$  and  $r = 4R/5$  then  $\Phi = Q/5\epsilon_0$

- Q.9 One mole of a monatomic ideal gas goes through a thermodynamic cycle, as shown in the volume versus temperature ( $V$ - $T$ ) diagram. The correct statement(s) is/are:  
[ $R$  is the gas constant]

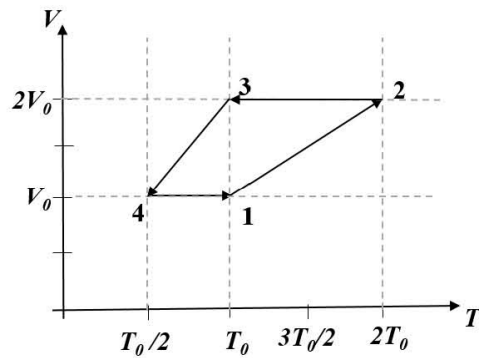

- (A) Work done in this thermodynamic cycle ( $1 \rightarrow 2 \rightarrow 3 \rightarrow 4 \rightarrow 1$ ) is  $|W| = \frac{1}{2}RT_0$
- (B) The above thermodynamic cycle exhibits only isochoric and adiabatic processes.
- (C) The ratio of heat transfer during processes  $1 \rightarrow 2$  and  $2 \rightarrow 3$  is  $\left| \frac{Q_{1 \rightarrow 2}}{Q_{2 \rightarrow 3}} \right| = \frac{5}{3}$
- (D) The ratio of heat transfer during processes  $1 \rightarrow 2$  and  $3 \rightarrow 4$  is  $\left| \frac{Q_{1 \rightarrow 2}}{Q_{3 \rightarrow 4}} \right| = \frac{1}{2}$

- Q.10 A thin convex lens is made of two materials with refractive indices  $n_1$  and  $n_2$ , as shown in figure. The radius of curvature of the left and right spherical surfaces are equal.  $f$  is the focal length of the lens when  $n_1 = n_2 = n$ . The focal length is  $f + \Delta f$  when  $n_1 = n$  and  $n_2 = n + \Delta n$ . Assuming  $\Delta n \ll (n - 1)$  and  $1 < n < 2$ , the correct statement(s) is/are,

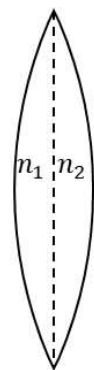

- A)  $\left| \frac{\Delta f}{f} \right| < \left| \frac{\Delta n}{n} \right|$
- B) For  $n = 1.5$ ,  $\Delta n = 10^{-3}$  and  $f = 20$  cm, the value of  $|\Delta f|$  will be 0.02 cm (round off to 2<sup>nd</sup> decimal place).
- (C) If  $\frac{\Delta n}{n} < 0$  then  $\frac{\Delta f}{f} > 0$
- D) The relation between  $\frac{\Delta f}{f}$  and  $\frac{\Delta n}{n}$  remains unchanged if both the convex surfaces are replaced by concave surfaces of the same radius of curvature.
- Q.11 Let us consider a system of units in which mass and angular momentum are dimensionless. If length has dimension of  $L$ , which of the following statement(s) is/are correct?
- (A) The dimension of linear momentum is  $L^{-1}$
- (B) The dimension of energy is  $L^{-2}$
- (C) The dimension of force is  $L^{-3}$
- (D) The dimension of power is  $L^{-5}$
- Q.12 Two identical moving coil galvanometers have  $10 \Omega$  resistance and full scale deflection at  $2 \mu\text{A}$  current. One of them is converted into a voltmeter of 100 mV full scale reading and the other into an Ammeter of 1mA full scale current using appropriate resistors. These are then used to measure the voltage and current in the Ohm's law experiment with  $R = 1000 \Omega$  resistor by using an ideal cell. Which of the following statement(s) is/are correct?
- (A) The resistance of the Voltmeter will be  $100 \text{ k}\Omega$
- (B) The resistance of the Ammeter will be  $0.02 \Omega$  (round off to 2<sup>nd</sup> decimal place)
- (C) The measured value of  $R$  will be  $978 \Omega < R < 982 \Omega$
- (D) If the ideal cell is replaced by a cell having internal resistance of  $5 \Omega$  then the measured value of  $R$  will be more than  $1000 \Omega$



### SECTION 3 (Maximum Marks: 18)

- This section contains **SIX (06)** questions. The answer to each question is a **NUMERICAL VALUE**.
- For each question, enter the correct numerical value of the answer using the mouse and the on-screen virtual numeric keypad in the place designated to enter the answer. If the numerical value has more than two decimal places, **truncate/round-off** the value to **TWO** decimal places.
- Answer to each question will be evaluated according to the following marking scheme:  
*Full Marks* : +3 If **ONLY** the correct numerical value is entered;  
*Zero Marks* : 0 In all other cases.

- Q.13 A particle is moved along a path AB-BC-CD-DE-EF-FA, as shown in figure, in presence of a force  $\vec{F} = (\alpha y\hat{i} + 2\alpha x\hat{j})$  N, where  $x$  and  $y$  are in meter and  $\alpha = -1 \text{ Nm}^{-1}$ . The work done on the particle by this force  $\vec{F}$  will be \_\_\_ Joule.

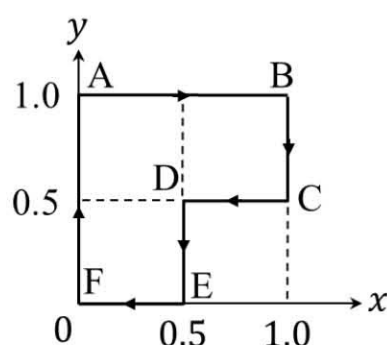

- Q.14 A block of weight 100 N is suspended by copper and steel wires of same cross sectional area  $0.5 \text{ cm}^2$  and, length  $\sqrt{3}$  m and 1 m, respectively. Their other ends are fixed on a ceiling as shown in figure. The angles subtended by copper and steel wires with ceiling are  $30^\circ$  and  $60^\circ$ , respectively. If elongation in copper wire is  $(\Delta l_c)$  and elongation in steel wire is  $(\Delta l_s)$ , then the ratio  $\frac{\Delta l_c}{\Delta l_s}$  is \_\_\_.

[Young's modulus for copper and steel are  $1 \times 10^{11} \text{ N/m}^2$  and  $2 \times 10^{11} \text{ N/m}^2$ , respectively.]

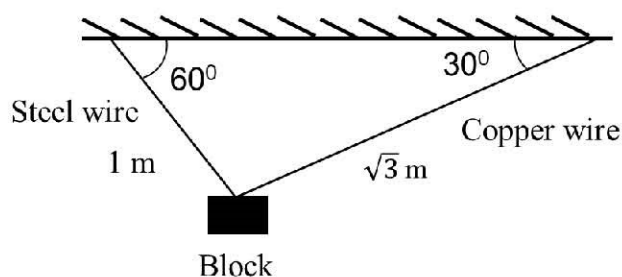

- Q.15 A train S1, moving with a uniform velocity of 108 km/h, approaches another train S2 standing on a platform. An observer O moves with a uniform velocity of 36 km/h towards S2, as shown in figure. Both the trains are blowing whistles of same frequency 120 Hz. When O is 600 m away from S2 and distance between S1 and S2 is 800 m, the number of beats heard by O is \_\_\_\_\_.
- [Speed of the sound = 330 m/s]

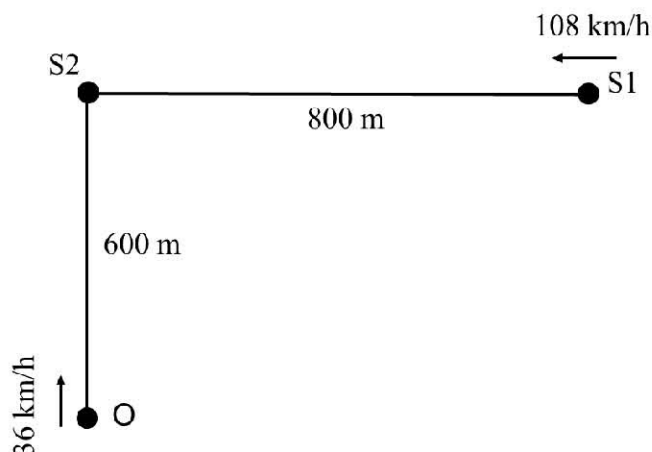

- Q.16 A parallel plate capacitor of capacitance  $C$  has spacing  $d$  between two plates having area  $A$ . The region between the plates is filled with  $N$  dielectric layers, parallel to its plates, each with thickness  $\delta = \frac{d}{N}$ . The dielectric constant of the  $m^{\text{th}}$  layer is  $K_m = K \left(1 + \frac{m}{N}\right)$ . For a very large  $N$  ( $> 10^3$ ), the capacitance  $C$  is  $\alpha \left(\frac{K\epsilon_0 A}{d \ln 2}\right)$ . The value of  $\alpha$  will be \_\_\_\_\_.
- [ $\epsilon_0$  is the permittivity of free space]
- Q.17 A liquid at  $30^\circ\text{C}$  is poured very slowly into a Calorimeter that is at temperature of  $110^\circ\text{C}$ . The boiling temperature of the liquid is  $80^\circ\text{C}$ . It is found that the first 5 gm of the liquid completely evaporates. After pouring another 80 gm of the liquid the equilibrium temperature is found to be  $50^\circ\text{C}$ . The ratio of the Latent heat of the liquid to its specific heat will be \_\_\_\_\_  $^\circ\text{C}$ .
- [Neglect the heat exchange with surrounding]

- Q.18 A planar structure of length  $L$  and width  $W$  is made of two different optical media of refractive indices  $n_1 = 1.5$  and  $n_2 = 1.44$  as shown in figure. If  $L \gg W$ , a ray entering from end AB will emerge from end CD only if the total internal reflection condition is met inside the structure. For  $L = 9.6$  m, if the incident angle  $\theta$  is varied, the maximum time taken by a ray to exit the plane CD is  $t \times 10^{-9}$  s, where  $t$  is \_\_\_\_\_.  
 [ Speed of light  $c = 3 \times 10^8$  m/s]

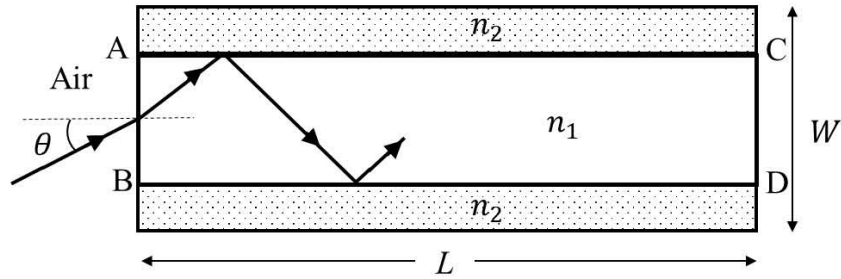

**JEE (ADVANCED) 2019 PAPER 1**  
**PART-II CHEMISTRY**

**SECTION 1 (Maximum Marks: 12)**

- This section contains **FOUR (04)** questions.
- Each question has **FOUR** options. **ONLY ONE** of these four options is the correct answer.
- For each question, choose the option corresponding to the correct answer.
- Answer to each question will be evaluated according to the following marking scheme:  
*Full Marks* : +3 If **ONLY** the correct option is chosen;  
*Zero Marks* : 0 If none of the options is chosen (i.e. the question is unanswered);  
*Negative Marks* : -1 In all other cases.

- Q.1 The green colour produced in the borax bead test of a chromium(III) salt is due to  
 (A)  $\text{Cr}(\text{BO}_2)_3$                       (B)  $\text{Cr}_2(\text{B}_4\text{O}_7)_3$                       (C)  $\text{Cr}_2\text{O}_3$                       (D)  $\text{CrB}$
- Q.2 Calamine, malachite, magnetite and cryolite, respectively, are  
 (A)  $\text{ZnSO}_4$ ,  $\text{CuCO}_3$ ,  $\text{Fe}_2\text{O}_3$ ,  $\text{AlF}_3$   
 (B)  $\text{ZnSO}_4$ ,  $\text{Cu}(\text{OH})_2$ ,  $\text{Fe}_3\text{O}_4$ ,  $\text{Na}_3\text{AlF}_6$   
 (C)  $\text{ZnCO}_3$ ,  $\text{CuCO}_3 \cdot \text{Cu}(\text{OH})_2$ ,  $\text{Fe}_3\text{O}_4$ ,  $\text{Na}_3\text{AlF}_6$   
 (D)  $\text{ZnCO}_3$ ,  $\text{CuCO}_3$ ,  $\text{Fe}_2\text{O}_3$ ,  $\text{Na}_3\text{AlF}_6$
- Q.3 Molar conductivity ( $\Lambda_m$ ) of aqueous solution of sodium stearate, which behaves as a strong electrolyte, is recorded at varying concentrations ( $c$ ) of sodium stearate. Which one of the following plots provides the correct representation of micelle formation in the solution? (critical micelle concentration (CMC) is marked with an arrow in the figures)

