

2007

**PI: Production and Industrial Engineering**

Duration : Three Hours

Maximum Marks :150

**Read the following instructions carefully.**

1. This question paper contains 85 objective type questions. Q.1 to Q.20 carry **one** mark each and Q.21 to Q.85 carry **two** marks each.
2. Attempt all the questions.
3. Questions must be answered on **Objective Response Sheet (ORS)** by darkening the appropriate bubble (marked A, B, C, D) using HB pencil against the question number on the left hand side of the **ORS**. **Each question has only one correct answer**. In case you wish to change an answer, erase the old answer completely.
4. Wrong answers will carry **NEGATIVE** marks. In Q.1 to Q.20, **0.25** mark will be deducted for each wrong answer. In Q.21 to Q.76, Q.78, Q.80, Q.82 and in Q.84, **0.5** mark will be deducted for each wrong answer. However, there is no negative marking in Q.77, Q.79, Q.81, Q.83 and in Q.85. More than one answer bubbled against a question will be taken as an incorrect response. Unattempted questions will not carry any marks.
5. Write your registration number, your name and name of the examination centre at the specified locations on the right half of the **ORS**.
6. Using HB pencil, darken the appropriate bubble under each digit of your registration number and the letters corresponding to your paper code.
7. Calculator is allowed in the examination hall.
8. Charts, graph sheets or tables are **NOT** allowed in the examination hall.
9. Rough work can be done on the question paper itself. Additionally blank pages are given at the end of the question paper for rough work.
10. This question paper contains **20** printed pages including pages for rough work. Please check all pages and report, if there is any discrepancy.

Q. 1 – Q. 20 carry one mark each.

Q.1 If a complex variable  $z = \frac{\sqrt{3}}{2} + i\frac{1}{2}$ , then  $z^4$  is

- (A)  $2\sqrt{3} + i \cdot 2$       (B)  $-\frac{1}{2} + i\frac{\sqrt{3}}{2}$       (C)  $\frac{\sqrt{3}}{2} - i\frac{1}{2}$       (D)  $\frac{\sqrt{3}}{8} + i\frac{1}{8}$

Q.2 Two cards are drawn at random in succession, with replacement, from a deck of 52 well shuffled cards. Probability of getting both 'Aces' is

- (A) 1/169      (B) 2/169      (C) 1/13      (D) 2/13

Q.3 The angle (in degrees) between two planar vectors  $\vec{a} = \frac{\sqrt{3}}{2}i + \frac{1}{2}j$  and  $\vec{b} = -\frac{\sqrt{3}}{2}i + \frac{1}{2}j$  is

- (A) 30      (B) 60      (C) 90      (D) 120

Q.4 What is the value of

$$\lim_{x \rightarrow \frac{\pi}{4}} \frac{\cos x - \sin x}{x - \frac{\pi}{4}}$$

- (A)  $\sqrt{2}$       (B) 0  
(C)  $-\sqrt{2}$       (D) Limit does not exist

Q.5 The determinant  $\begin{vmatrix} 1+b & b & 1 \\ b & 1+b & 1 \\ 1 & 2b & 1 \end{vmatrix}$  evaluates to

- (A) 0      (B)  $2b(b-1)$       (C)  $2(1-b)(1+2b)$       (D)  $3b(1+b)$

Q.6  $f(x) = |x|$  is a function defined for real numbers  $x$ . The directional derivative of  $f$  at  $x=0$  in the direction  $d = -1$  is

- (A) 1      (B) 0      (C)  $-1/2$       (D)  $-1$

Q.7 Which one of the following planar mechanisms does NOT provide quick-return motion?

- (A) Scotch-Yoke      (B) Whitworth  
(C) Off-set slider crank      (D) Drag link

- Q.8 The geometric tolerance that does NOT need a datum for its specification is  
 (A) Concentricity (B) Runout (C) Perpendicularity (D) Flatness
- Q.9 Oil in a hydraulic cylinder is compressed from an initial volume of  $2 \text{ m}^3$  to  $1.96 \text{ m}^3$ . If the pressure of oil in the cylinder changes from 40 MPa to 80 MPa during compression, the bulk modulus of elasticity of oil is  
 (A) 1000 MPa (B) 2000 MPa (C) 4000 MPa (D) 8000 MPa
- Q.10 A component made of a material with a modulus of elasticity of 200 MPa and modulus of rigidity of 80 MPa experiences an axial strain of 1000. The lateral strain experienced by the component within the elastic limit is  
 (A) 250 (B) 400 (C) 500 (D) 800
- Q.11 Which one of the following cooling methods is best suited for converting Austenite steel into very fine Pearlite steel?  
 (A) Oil quenching (B) Water quenching  
 (C) Air cooling (D) Furnace cooling
- Q.12 Reaming is primarily used for achieving  
 (A) Higher MRR (B) Improved dimensional tolerance  
 (C) Fine surface finish (D) Improved positional tolerance
- Q.13 The *interpolator* in a CNC machine controls  
 (A) Spindle speed (B) Coolant flow  
 (C) Feed rate (D) Tool change
- Q.14 Which one of the following instruments is a *comparator*?  
 (A) Tool Maker's Microscope (B) GO/NO GO gage  
 (C) Optical Interferometer (D) Dial Gauge
- Q.15 Which one of the following is an indispensable part of Just-in-Time manufacturing of multiple products on a line?  
 (A) Outbound quality inspection (B) Lot sizing  
 (C) Safety stocks (D) Set up time reduction
- Q.16 During an economic analysis of a capital investment proposal, the cost that can be ignored is  
 (A) Sunk cost (B) Fixed cost  
 (C) Marginal cost (D) Variable cost



Q.24 The function  $e^x$  over the interval  $[0,1]$  is to be evaluated using the Taylor series  $1+x+\frac{x^2}{2!}+\frac{x^3}{3!}+\dots$  to an accuracy of  $\delta > 0$ . The number of terms in the series that is considered for this accuracy is  $n$ . Then

- (A) for a given  $x \in [0,1]$  and a given  $\delta$ , there is no finite  $n$  that is valid
- (B) for a given  $\delta > 0$ , there is a valid  $n$  that is finite for a given  $x \in [0,1]$ , but there is no finite  $n$  that is valid for all  $x \in [0,1]$
- (C) for a given  $\delta > 0$ , there is a finite  $n$  that is valid for all  $x \in [0,1]$
- (D) there is a finite  $n$  that is valid for all  $x$  in  $[0,1]$  and all  $\delta > 0$

Q.25 For the function  $f(x, y) = x^2 - y^2$  defined on  $R^2$ , the point  $[0,0]$  is

- (A) a local minimum
- (B) a local maximum
- (C) neither a local minimum nor a local maximum
- (D) both a local minimum and a local maximum

Q.26  $q_1, \dots, q_m$  are  $n$ -dimensional vectors, with  $m < n$ . This set of vectors is linearly dependent.  $Q$  is the matrix with  $q_1, \dots, q_m$  as the columns. The rank of  $Q$  is

- (A) Less than  $m$
- (B)  $m$
- (C) between  $m$  and  $n$
- (D)  $n$

Q.27 "Matching Exercise". Choose the correct one out of the alternatives A,B,C,D

Group 1	Group 2
P – Second order differential equations	1 – Runge-Kutta method
Q – Nonlinear algebraic equations	2 – Newton-Raphson method
R – Linear algebraic equations	3 – Gauss elimination
S – Numerical integration	4 – Simpson's rule

- (A) P-3, Q-2, R-4, S-1
- (B) P-2, Q-4, R-3, S-1
- (C) P-1, Q-2, R-3, S-4
- (D) P-1, Q-3, R-2, S-4

Q.28 A disc type flywheel having a mass of 10 kg and radius 0.2 m is replaced in a single cylinder engine by a system of dynamically equivalent concentrated masses  $m_1$  and  $m_2$  rotating about the flywheel axis as shown below. If the distance  $x_1$  is 0.1 m then the distance  $x_2$  is

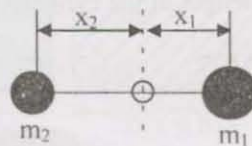

- (A) 0.1 m
- (B) 0.2 m
- (C) 0.4 m
- (D) 0.8 m

Q.29 A radial disc cam rotating at a constant speed of 60 rpm provides a parabolic displacement of 0.2 m to its flat faced rectilinear follower during  $90^\circ$  of its rotation. The acceleration ( $\text{m/s}^2$ ) experienced by the follower is

- (A) 0.8 (B) 1.6 (C) 3.2 (D) 6.4

Q.30 Figure below shows a mass of 300 kg being pushed using a cylindrical rod made of a material having  $E = 22 \text{ MPa}$  and of 2 m length and 0.1 m in diameter. In order to avoid the failure of the rod due to elastic instability, the maximum value of the coefficient of Coulomb friction permissible between the mass and the floor is



- (A) 0.22 (B) 0.36 (C) 0.65 (D) 0.75

Q.31 A cylindrical tank is filled with water as shown in the Figure below. The force required to close the discharge tube at the bottom of the tank is

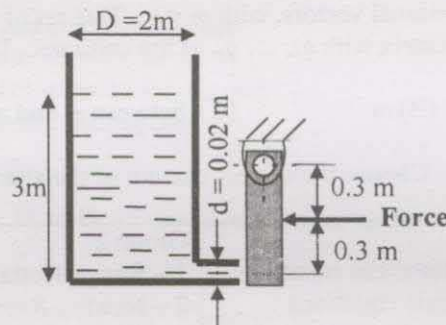

- (A) 18.5 N (B) 37 N (C) 45.5 N (D) 74 N

Q.32 When an ideal gas ( $C_p = 3.5$ ) is heated at constant pressure from  $25^\circ\text{C}$  to  $425^\circ\text{C}$ , the change in entropy is

- (A) 1.48 (B) 2.97 (C) 4.2 (D) 5.98

Q.33 A long glass cylinder of inner diameter = 0.03 m and outer diameter = 0.05 m carries hot fluid inside. If the thermal conductivity of glass =  $1.05 \text{ W/mK}$ , the thermal resistance ( $^\circ\text{K/W}$ ) per unit length of the cylinder is

- (A) 0.031 (B) 0.077 (C) 0.17 (D) 0.34

Q.34 A tool with Side Cutting Edge angle of  $30^\circ$  and End Cutting Edge angle of  $10^\circ$  is used for fine turning with a feed of 1 mm/rev. Neglecting nose radius of the tool, the maximum (peak to valley) height of surface roughness produced will be

- (A) 0.16 mm (B) 0.26 mm (C) 0.32 mm (D) 0.48 mm

Q.35 Which one of the following process conditions leads to higher MRR in ECM process?

- (A) higher current, larger atomic weight      (B) higher valency, lower current  
 (C) lower atomic weight, lower valency      (D) higher valency, lower atomic weight

Q.36 In an Abrasive Jet Machining process, if  $Q$  = flow rate of the abrasives and  $d$  = the mean diameter of the abrasive grain, then material removal rate is proportional to

- (A)  $Q/d^2$       (B)  $Qd$       (C)  $Qd^2$       (D)  $Qd^3$

Q.37 "Matching Exercise". Choose the correct one out of the alternatives A, B, C, D

Group 1 P – Plastic Carry-bags Q – O-rings R – Shrink Wrappers S – Automobile Dashboards	Group 2 1 – Thermo-Vacuum Forming 2 – Blow Molding 3 – Compression Molding 4 – Resin Transfer Molding
--	---

- (A) P-2, Q-3, R-1, S-4      (B) P-1, Q-2, R-3, S-4  
 (C) P-3, Q-4, R-1, S-2      (D) P-2, Q-3, R-4, S-1

Q.38 "Matching Exercise". Choose the correct one out of the alternatives A, B, C, D

Group 1 P – Sand Casting Q – Centrifugal Casting R – Investment Casting S – Die Casting	Group 2 1 – Turbine blades 2 – I.C. Engine Pistons 3 – Large bells 4 – Pulleys
---	--

- (A) P-4, Q-1, R-3, S-2      (B) P-2, Q-4, R-3, S-1  
 (C) P-3, Q-4, R-1, S-2      (D) P-3, Q-2, R-1, S-4

Q.39 Tolerance on the dimension  $x$  in the two component assembly shown below is

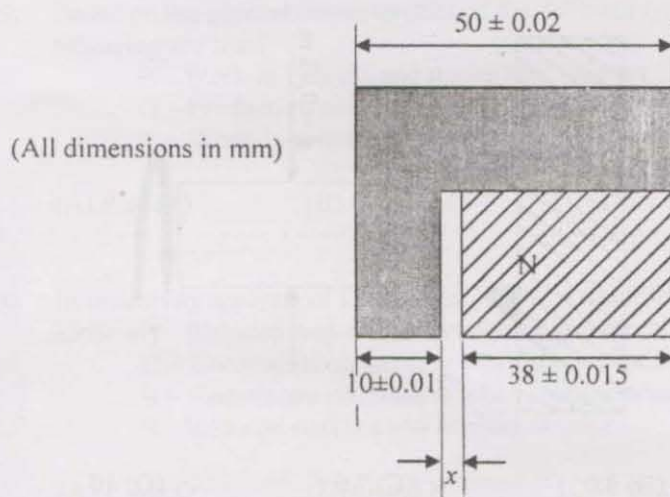

- (A)  $\pm 0.025$       (B)  $\pm 0.030$       (C)  $\pm 0.040$       (D)  $\pm 0.045$

Q.40 The maximum possible percentage reduction in area per pass during wire drawing of an ideal plastic material without friction is of the order of

- (A) 37 (B) 50 (C) 63 (D) 75

Q.41 Circular blanks of 35 mm diameter are punched from a steel sheet of 2 mm thickness. If the clearance per side between the punch and die is to be kept as 40 microns, the sizes of punch and die should respectively be

- (A)  $35^{+0.00}$  and  $35^{+0.040}$  (B)  $35^{-0.040}$  and  $35^{-0.080}$   
 (C)  $35^{+0.00}$  and  $35^{+0.080}$  (D)  $35^{+0.040}$  and  $35^{-0.080}$

Q.42 In a CAD package, a point P (6, 3, 2) is projected along a vector  $v(-2, 1, -1)$ . The projection of this point on X-Y plane will be

- (A) (4, 4, 0) (B) (8, 2, 0) (C) (7, 4, 0) (D) (2, 5, 0)

Q.43

The geometric transformation specified by  $[x' y' 1] = [x y 1] \begin{bmatrix} 0.5 & 0 & 0 \\ 0 & 0.25 & 0 \\ 1 & 2 & 1 \end{bmatrix}$  in a 2D

CAD system represents

- (A) Scaling and Translation (B) Scaling and Rotation  
 (C) Rotation and Translation (D) Rotation

Q.44 The figure below shows the cross-section of circular fillet weld joining a cylindrical steel pin to a steel plate. If the pin is subjected to a pure torsional load, the shear stress (MPa) occurring at the throat of the weld is

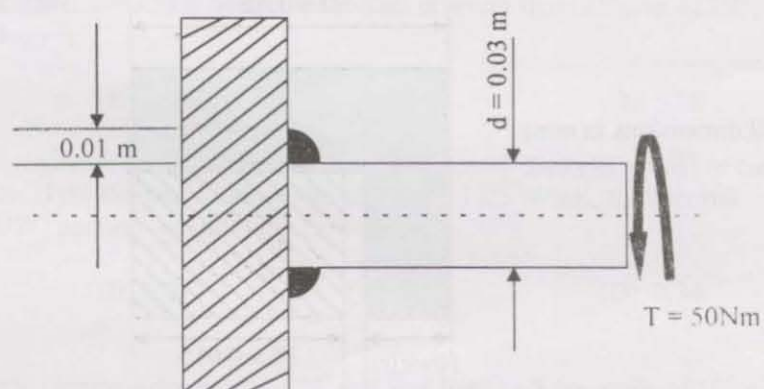

- (A) 2.5 (B) 5.0 (C) 7.0 (D) 10



Q.45

Diameter of a hole after plating needs to be controlled between  $30^{+0.010}$  mm. If the plating thickness varies between 10-15 microns, diameter of the hole before plating should be

- (A)  $30^{+0.030}$  mm                      (B)  $30^{+0.020}$  mm  
(C)  $30^{+0.030}$  mm                      (D)  $30^{+0.040}$  mm

Q.46 The D.C. power source for arc welding has the characteristic  $3V + I = 240$ , where  $V =$  Voltage and  $I =$  Current in amp. For maximum arc power at the electrode, voltage should be set at

- (A) 20 V                      (B) 40 V                      (C) 60 V                      (D) 80 V

Q.47 In a CNC machine feed drive, a stepper motor with step angle of  $1.8^\circ$  drives a lead screw with pitch of 2 mm. The Basic Length Unit (BLU) for this drive is

- (A) 10 microns                      (B) 20 microns                      (C) 40 microns                      (D) 100 microns

Q.48 Which one of the following gear manufacturing processes is NOT based on generation principle?

- (A) Gear Hobbing                      (B) Gear Shaping  
(C) Gear Milling                      (D) Gear Shaving

Q.49 Based on the general characteristics of the different types of layout, which of the following are true?

- P – Work-in-process and throughput time are high in process layout  
Q – Production cost per unit is high in product layout  
R – Work-in-process and throughput time are high in product layout

- (A) P and Q                      (B) Q and R                      (C) Only P                      (D) Only R

Q.50 In sensitivity analysis of LP models, which of the following holds true?

- P – Reduced cost of basic variables are zero at optimality  
Q – Constraints are binding when shadow prices are non-zero  
R – Constraints are binding when shadow prices are zero  
S – Reduced cost is same as shadow price

- (A) P and Q                      (B) Q and R                      (C) P and R                      (D) Q and S

- Q.51 Consider the symmetric dual pair of LPs [P] and [D], where  $\mathbf{A}$  is an  $m \times n$  matrix,  $\mathbf{b}$  is an  $m$ -vector and  $\mathbf{c}$  is an  $n$ -vector.

$$\begin{array}{l|l} \text{[P]} \text{ Min } & \mathbf{c}^T \mathbf{x} \\ \text{s.t.} & \mathbf{Ax} \geq \mathbf{b} \\ & x \geq 0 \end{array} \quad \begin{array}{l|l} \text{[D]} \text{ Max } & \mathbf{b}^T \mathbf{y} \\ \text{s.t.} & \mathbf{A}^T \mathbf{y} \leq \mathbf{c}^T \\ & y \geq 0 \end{array}$$

Assume that [P] is feasible. If the optimal values are  $z_1^*$  for [P] and  $z_2^*$  for [D], whenever they exist, then which one of the following is true?

- (A) If [D] is infeasible, then  $z_1^*$  can be determined and is equal to  $z_2^*$   
 (B) If [D] is feasible, then  $z_1^*$  cannot be determined  
 (C) If [D] is feasible, then  $z_1^*$  can be determined and is equal to  $z_2^*$   
 (D) If [D] is feasible, then  $z_1^*$  can be determined but not equal to  $z_2^*$

- Q.52 The moving average method is to be used for forecasting demand based on  $m$  periods of data. Two values of  $m$  are tried,  $m_1$  and  $m_2$  with  $m_1 > m_2$ , to get two different forecasts, denoted by  $F(t)$  and  $G(t)$ .

P –  $F(t)$  has less variability than  $G(t)$

Q – Forecast error of  $F(t)$  is less than that of  $G(t)$

Which of the above statements are true?

- (A) Only P                      (B) Only Q                      (C) Both P and Q                      (D) Neither P nor Q
- Q.53 In an optimization problem, let  $y$  be a 0–1 variable and  $x$  be a positive real number. Now, the condition that  $x$  can take non-zero values only if  $y = 1$  can be modeled using the linear constraint

- (A)  $x \leq My$  ( $M$  is a large number)                      (B)  $x \geq y$   
 (C)  $x \geq My$  ( $M$  is a large number)                      (D)  $xy \geq 0$

- Q.54 The average number of accidents occurring monthly on an assembly shop floor is 2. The probability that there will be at least one accident in this month is estimated to be

- (A) 0.055                      (B) 0.456                      (C) 0.865                      (D) 0.950

- Q.55  $X_1, \dots, X_{100}$  are Bernoulli random variables with a probability of success equal to 0.6.

By the Central Limit Theorem, the random variable  $Y = \sum_{i=1, \dots, 100} X_i$  is approximately normally distributed. Then  $Y$  has mean and variance respectively equal to

- (A) 40 and 24                      (B) 60 and 24                      (C) 40 and 12                      (D) 60 and 12

- Q.56 Karmarkar's algorithm for Linear Programming

- (A) moves along different extreme point solutions of the feasible region  
 (B) enumerates all possible extreme point solutions  
 (C) divides the feasible region into different parts for function evaluation  
 (D) generates interior point iterates which converges to the optimum solution

Q.57 For a transportation problem that has a feasible solution, the northwest corner rule gives a possible solution which is

- (A) a basic feasible solution to the problem
- (B) a near optimal solution to the problem
- (C) the optimal solution to the problem
- (D) one of the many optimal solutions to the problem

Q.58 The assignment problem in Linear Programming is also an example of a discrete optimization problem. How many feasible solutions are there to this problem defined on  $n$  jobs and  $n$  persons?

- (A)  $n^n$
- (B)  $n(n-1)$
- (C)  $n^2$
- (D)  $n!$

Q.59 "Matching Exercise". Choose the correct one out of the alternatives A,B,C,D

Group 1	Group 2
P – Knowledge Based System	1 – responds to queries with reports
Q – Decision Support System	2 – uses statistical rules of inference
R – Management Information System	3 – provides recommendations
S – Data Mining	4 – uses reasoning techniques

- (A) P-4, Q-3, R-1, S-2
- (B) P-2, Q-3, R-1, S-4
- (C) P-4, Q-2, R-3, S-1
- (D) P-3, Q-4, R-1, S-2

Q.60 A process is to be controlled with standard values  $\mu = 15$  and  $\sigma = 3.6$ . The sample size is 9. The control limits for the  $\bar{X}$  chart are

- (A)  $15 \pm 10.8$
- (B)  $15 \pm 3.6$
- (C)  $0.4 \pm 10.8$
- (D)  $0.4 \pm 3.6$

Q.61 Item P is made from components Q and R. Item Q, in turn, is made from S and T. The lead times for items P, Q, R, S, and T are 2, 3, 10, 5, and 6 weeks, respectively. The lead time (in weeks) needed to respond to a customer order for item P is

- (A) 10
- (B) 11
- (C) 12
- (D) 26

Q.62 The reliability of an equipment for a time to failure exceeding  $t$  is given by  $R(t) = \exp(-\lambda t)$ . The mean time to failure (MTTF) for this equipment (in hours) is

- (A)  $\lambda$
- (B)  $1/\lambda$
- (C)  $(1/\lambda^2)$
- (D)  $\lambda^2$

- Q.63 Four jobs have to be sequenced on a single facility, with the objective of minimizing the maximum tardiness ( $= \max_i |\text{Completion time}_i - \text{Due date}_i|$ ). The jobs have due dates and processing times as follows

Job	Due date (day number)	Processing time (days)
P	5	2
Q	6	10
R	3	3
S	7	4

The last job that should be taken up is

- (A) P                      (B) Q                      (C) R                      (D) S
- Q.64 An asset investment is made for Rs. 1,20,000. The uniform costs per year are Rs. 40,000 in operating the asset. Uniform benefits per year are either Rs. 60,000 or Rs. 80,000, judged to be equally likely. What is the expected payback period?

- (A) 3                      (B) 4.5                      (C) 6                      (D) 9

Q.65

Activity	Time (minutes)
machine loading + unloading	2
machining	4
walking from one machine to the next	1

For the data given above, how many machines can be assigned to an operator to minimize idle time of the operator and machines?

- (A) 1                      (B) 2                      (C) 3                      (D) 4
- Q.66 Given
- Assertion [a]:** Value engineering of a new product is to be done after the original design concept is nearly ready for release for manufacture
- Reason [r]:** Value engineering aims at reducing the cost of manufacture of a new product

- (A) Both [a] and [r] are true and [r] is the correct reason for [a]  
 (B) Both [a] and [r] are true, but [r] is not the correct reason for [a]  
 (C) Both [a] and [r] are false  
 (D) [a] is true but [r] is false

Q.67 Given

**Assertion [a]:** There is a continuous reduction of life cycles of modern day products

**Reason [r]:** Product life cycle management reduces to a large extent the new product development time from concept to production

- (A) Both [a] and [r] are true and [r] is the correct reason for [a]
- (B) Both [a] and [r] are true, but [r] is not the correct reason for [a]
- (C) Both [a] and [r] are false
- (D) [a] is true but [r] is false

Q.68 The problem of finding the rectangle of maximum area with perimeter equal to 20 can be posed as the constrained optimization problem

$$\begin{array}{ll} \text{Max} & xy \\ \text{s.t.} & 2x + 2y = 20 \\ & x, y \geq 0 \end{array}$$

The solution to this problem is  $x = y = 5$ . What is the value of the Lagrange multiplier corresponding to the perimeter constraint?

- (A) 2.5                      (B) 5                      (C) 7.5                      (D) 10

Q.69 A manufacturing system with a production rate  $p$  units/day experiences a demand rate of  $d$  units/day where  $p > d$ . Let  $Q$  be the maximum production quantity per period. When the total production in a period reaches  $Q$  units, the production is stopped and restarted only when inventory becomes zero. In such a scenario, the maximum cycle inventory is

- (A)  $Q \cdot p \cdot (p - d)$       (B)  $\frac{Q}{(p - d)} p$       (C)  $\frac{Q}{p} (p - d)$       (D)  $\frac{p(p - d)}{Q}$

Q.70 In a time study, the observed times and ratings for an elemental operation are as shown below:

	Reading 1	Reading 2
Rating (%)	80	100
Observed time (minutes)	0.60	0.50

Considering an allowance of 10% of the normal time, the standard time (in minutes) for the operation is

- (A) 0.49                      (B) 0.54                      (C) 0.98                      (D) 1.08

### Common Data Questions

**Common Data for Questions 71,72,73:**

The figure below illustrates a project network describing the precedence relationships among different activities (A-J). The activities along with their duration in weeks are represented as arcs, and the events are shown as nodes (1 is the start event and 9 is the end event).

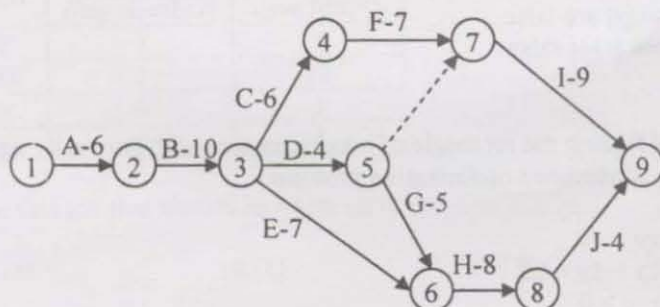

- Q.71 The length of the critical path in weeks is  
 (A) 29 (B) 31 (C) 38 (D) 66
- Q.72 If  $U_\alpha$  is the earliest start time of event  $\alpha$ , then the recurrence equation defining  $U_6$  is  
 (A)  $U_6 = \text{Max}\{U_8, 8\}$  (B)  $U_6 = U_8 - 8$   
 (C)  $U_6 = \text{Max}\{U_3, U_5, 7, 5\}$  (D)  $U_6 = \text{Max}\{U_3 + 7, U_5 + 5\}$
- Q.73 If activity B has uncertain duration and is uniformly distributed over the interval [8, 12], and  $T$  is the earliest start time of event 3 (assume that event 1 starts at time 0), then the mean and variance of  $T$  are  
 (A) 10 and 0.4 (B) 10 and 1.33 (C) 16 and 0.4 (D) 16 and 1.33

**Common Data for Questions 74, 75:**

In an orthogonal machining test, the following observations were made

Cutting force	1200 N
Thrust force	500 N
Tool rake angle	Zero
Cutting speed	1 m/s
Depth of cut	0.8 mm
Chip thickness	1.5 mm

- Q.74 Friction angle during machining will be  
 (A)  $22.6^\circ$  (B)  $32.8^\circ$  (C)  $57.1^\circ$  (D)  $67.4^\circ$
- Q.75 Chip speed along the tool rake face will be  
 (A) 0.83 m/s (B) 0.53 m/s (C) 1.2 m/s (D) 1.88 m/s

**Linked Answer Questions: Q.76 to Q.85 carry two marks each.**

**Statement for Linked Answer Questions 76 & 77:**

In the setup shown below, 2kW power is supplied by oil flowing into the cylinder of the hydraulic actuator at the rate of  $400 \times 10^{-6} \text{ m}^3/\text{s}$ .

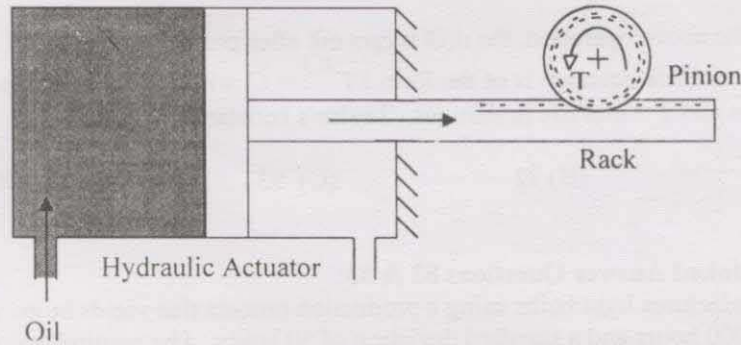

- Q.76 If the diameter of the piston is 0.05 m, the force (kN) generated on the piston is  
 (A) 1.6 (B) 4.8 (C) 9.8 (D) 12.2
- Q.77 The pinion is a spur gear having 30 teeth of 2 mm module. The torque T (Nm) generated is  
 (A) 36 (B) 72 (C) 147 (D) 294

**Statement for Linked Answer Questions 78 & 79:**

Consider an unbalanced serial assembly line consisting of three workstations that produces a single part. The part visits each workstation exactly once. The number of parallel machines at each workstation and the processing time at a machine is shown below:

Workstation	Number of machines	Processing time (minutes)
1	1	2
2	2	5
3	6	10

- Q.78 What is the capacity (in parts/minute) of the above assembly line?  
 (A) 0.1 (B) 0.4 (C) 0.5 (D) 0.6
- Q.79 The minimum WIP level that allows the line to operate under maximum capacity is  
 (A) 1.7 (B) 4.0 (C) 6.8 (D) 8.6

**Statement for Linked Answer Questions 80 & 81:**

Blind holes 10 mm diameter, 50 mm deep are being drilled in steel block. Drilling spindle speed is 600 rpm, feed 0.2 mm/rev, Point angle of drill is  $120^\circ$ .

- Q.80 Machining time (in minutes) per hole will be  
(A) 0.08 (B) 0.31 (C) 0.44 (D) 0.86
- Q.81 During the above operation, the drill wears out after producing 200 holes. Taylor's tool life equation is of the form  $VT^{0.3} = C$ , where  $V$  = cutting speed in m/minute and  $T$  = tool life in minutes. Taylor's constant  $C$  will be  
(A) 15 (B) 72 (C) 93 (D) 490

**Statement for Linked Answer Questions 82 & 83:**

A company manufactures light bulbs using a production process that yields bulbs with an average life of 1000 hours and a standard deviation of 50 hours. The nominal value, USL and LSL are 1100 hours, 1300 hours, and 900 hours respectively.

- Q.82 The process capability index ( $C_{pk}$ ) for the manufacturing process is  
(A) 0.67 (B) 1.00 (C) 1.33 (D) 2.00
- Q.83 For the above manufacturing process, the ratio of the potential process capability to its actual process capability is  
(A) 0.50 (B) 0.67 (C) 1.00 (D) 2.00

**Statement for Linked Answer Questions 84 & 85:**

In a sand casting process, a sprue of 10 mm base diameter and 250 mm height leads to a runner which fills a cubical mould cavity of 100 mm size

- Q.84 The volume flow rate (in  $\text{mm}^3/\text{s}$ ) is  
(A)  $0.8 \times 10^5$  (B)  $1.1 \times 10^5$  (C)  $1.7 \times 10^5$  (D)  $2.3 \times 10^5$
- Q.85 The mould filling time (in seconds) is  
(A) 2.8 (B) 5.78 (C) 7.54 (D) 8.41

**END OF THE QUESTION PAPER**