

CS : COMPUTER SCIENCE AND INFORMATION TECHNOLOGY*Duration: Three Hours**Maximum Marks: 100***Read the following instructions carefully.**

1. This question paper contains **24** pages including blank pages for rough work. Please check all pages and report discrepancy, if any.
2. Write your registration number, your name and name of the examination centre at the specified locations on the right half of the **Optical Response Sheet (ORS)**.
3. Using **HB** pencil, darken the appropriate bubble under each digit of your registration number and the letters corresponding to your paper code.
4. All questions in this paper are of objective type.
5. Questions must be answered on the **ORS** by darkening the appropriate bubble (marked A, B, C, D) using **HB** pencil against the question number on the left hand side of the ORS. **For each question darken the bubble of the correct answer.** In case you wish to change an answer, erase the old answer completely. More than one answer bubbled against a question will be treated as an incorrect response.
6. There are a total of 65 questions carrying 100 marks.
7. Questions Q.1 – Q.25 will carry 1-mark each, and questions Q.26 – Q.55 will carry 2-marks each.
8. Questions Q.48 – Q.51 (2 pairs) are common data questions and question pairs (Q.52, Q.53) and (Q.54, Q.55) are linked answer questions. The answer to the second question of the linked answer questions depends on the answer to the first question of the pair. If the first question in the linked pair is wrongly answered or is un-attempted, then the answer to the second question in the pair will not be evaluated.
9. Questions Q.56 – Q.65 belong to General Aptitude (GA). Questions Q.56 – Q.60 will carry 1-mark each, and questions Q.61 – Q.65 will carry 2-marks each. The GA questions will begin on a fresh page starting from page 15.
10. Un-attempted questions will carry zero marks.
11. Wrong answers will carry **NEGATIVE** marks. For Q.1 – Q.25 and Q.56 – Q.60, $\frac{1}{2}$ mark will be deducted for each wrong answer. For Q.26 – Q.51 and Q.61 – Q.65, $\frac{2}{3}$ mark will be deducted for each wrong answer. The question pairs (Q.52, Q.53), and (Q.54, Q.55) are questions with linked answers. There will be negative marks only for wrong answer to the first question of the linked answer question pair i.e. for Q.52 and Q.54, $\frac{2}{3}$ mark will be deducted for each wrong answer. There is no negative marking for Q.53 and Q.55.
12. Calculator (without data connectivity) is allowed in the examination hall.
13. Charts, graph sheets or tables are **NOT** allowed in the examination hall.
14. Rough work can be done on the question paper itself. Additionally, blank pages are provided at the end of the question paper for rough work.

Q.1 – Q.25 carry one mark each.

- Q.1 Let $G = (V, E)$ be a graph. Define $\xi(G) = \sum_d i_d \times d$, where i_d is the number of vertices of degree d in G . If S and T are two different trees with $\xi(S) = \xi(T)$, then
 (A) $|S| = 2|T|$ (B) $|S| = |T| - 1$ (C) $|S| = |T|$ (D) $|S| = |T| + 1$
- Q.2 Newton-Raphson method is used to compute a root of the equation $x^2 - 13 = 0$ with 3.5 as the initial value. The approximation after one iteration is
 (A) 3.575 (B) 3.677 (C) 3.667 (D) 3.607
- Q.3 What is the possible number of reflexive relations on a set of 5 elements?
 (A) 2^{10} (B) 2^{15} (C) 2^{20} (D) 2^{25}
- Q.4 Consider the set $S = \{1, \omega, \omega^2\}$, where ω and ω^2 are cube roots of unity. If $*$ denotes the multiplication operation, the structure $\{S, *\}$ forms
 (A) a group (B) a ring (C) an integral domain (D) a field
- Q.5 What is the value of $\lim_{n \rightarrow \infty} \left(1 - \frac{1}{n}\right)^{2n}$?
 (A) 0 (B) e^{-2} (C) $e^{-1/2}$ (D) 1
- Q.6 The minterm expansion of $f(P, Q, R) = PQ + Q\bar{R} + P\bar{R}$ is
 (A) $m_2 + m_4 + m_6 + m_7$ (B) $m_0 + m_1 + m_3 + m_5$
 (C) $m_0 + m_1 + m_6 + m_7$ (D) $m_2 + m_3 + m_4 + m_5$
- Q.7 A main memory unit with a capacity of 4 megabytes is built using $1M \times 1$ -bit DRAM chips. Each DRAM chip has 1K rows of cells with 1K cells in each row. The time taken for a single refresh operation is 100 nanoseconds. The time required to perform one refresh operation on all the cells in the memory unit is
 (A) 100 nanoseconds (B) 100×2^{10} nanoseconds
 (C) 100×2^{20} nanoseconds (D) 3200×2^{20} nanoseconds
- Q.8 P is a 16-bit signed integer. The 2's complement representation of P is $(F87B)_{16}$. The 2's complement representation of $8*P$ is
 (A) $(C3D8)_{16}$ (B) $(187B)_{16}$ (C) $(F878)_{16}$ (D) $(987B)_{16}$

Q.9 The Boolean expression for the output f of the multiplexer shown below is

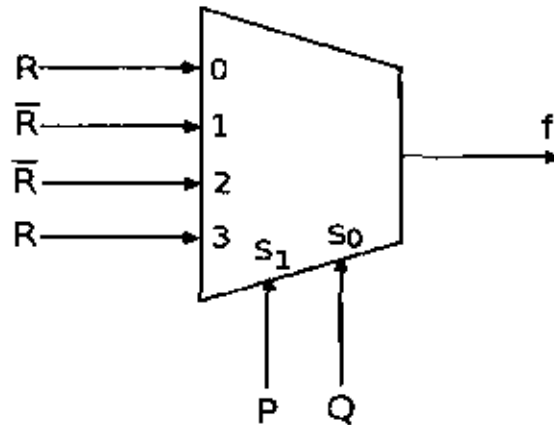

- (A) $\overline{P \oplus Q \oplus R}$ (B) $P \oplus Q \oplus R$ (C) $P + Q + R$ (D) $\overline{P + Q + R}$

Q.10 In a binary tree with n nodes, every node has an odd number of descendants. Every node is considered to be its own descendant. What is the number of nodes in the tree that have exactly one child?

- (A) 0 (B) 1 (C) $(n-1)/2$ (D) $n-1$

Q.11 What does the following program print?

```
#include <stdio.h>
void f(int *p, int *q){
    p = q;
    *p = 2;
}
int i=0, j=1;
int main(){
    f(&i, &j);
    printf("%d %d\n", i, j);
    return 0;
}
```

- (A) 2 2 (B) 2 1 (C) 0 1 (D) 0 2

Q.12 Two alternative packages A and B are available for processing a database having 10^k records. Package A requires $0.0001 n^2$ time units and package B requires $10 n \log_{10} n$ time units to process n records. What is the smallest value of k for which package B will be preferred over A?

- (A) 12 (B) 10 (C) 6 (D) 5

Q.13 Which data structure in a compiler is used for managing information about variables and their attributes?

- (A) Abstract syntax tree (B) Symbol table
(C) Semantic stack (D) Parse table

Q.14 Which languages necessarily need heap allocation in the runtime environment?

- (A) Those that support recursion.
(B) Those that use dynamic scoping.
(C) Those that allow dynamic data structures.
(D) Those that use global variables.

- Q.15 One of the header fields in an IP datagram is the Time-to-Live (TTL) field. Which of the following statements best explains the need for this field?
- (A) It can be used to prioritize packets.
 (B) It can be used to reduce delays.
 (C) It can be used to optimize throughput.
 (D) It can be used to prevent packet looping.
- Q.16 Which one of the following is not a client-server application?
- (A) Internet chat (B) Web browsing
 (C) E-mail (D) Ping
- Q.17 Let L_1 be a recursive language. Let L_2 and L_3 be languages that are recursively enumerable but not recursive. Which of the following statements is not necessarily true?
- (A) $L_2 - L_1$ is recursively enumerable.
 (B) $L_1 - L_3$ is recursively enumerable.
 (C) $L_2 \cap L_3$ is recursively enumerable.
 (D) $L_2 \cup L_3$ is recursively enumerable.
- Q.18 Consider a B^+ -tree in which the maximum number of keys in a node is 5. What is the minimum number of keys in any non-root node?
- (A) 1 (B) 2 (C) 3 (D) 4
- Q.19 A relational schema for a train reservation database is given below.

Passenger(pid, pname, age)
 Reservation(pid, class, tid)

Table: Passenger

pid	pname	Age
0	'Sachin'	65
1	'Rahul'	66
2	'Sourav'	67
3	'Anil'	69

Table: Reservation

pid	class	tid
0	'AC'	8200
1	'AC'	8201
2	'SC'	8201
5	'AC'	8203
1	'SC'	8204
3	'AC'	8202

What pids are returned by the following SQL query for the above instance of the tables?

```
SELECT pid
FROM Reservation
WHERE class = 'AC' AND
      EXISTS (SELECT *
              FROM Passenger
              WHERE age > 65 AND
                    Passenger.pid = Reservation.pid)
```

- (A) 1, 0 (B) 1, 2 (C) 1, 3 (D) 1, 5

Q.20 Which of the following concurrency control protocols ensure both conflict serializability and freedom from deadlock?

- I. 2-phase locking
- II. Time-stamp ordering

(A) I only (B) II only (C) Both I and II (D) Neither I nor II

Q.21 The cyclomatic complexity of each of the modules A and B shown below is 10. What is the cyclomatic complexity of the sequential integration shown on the right hand side?

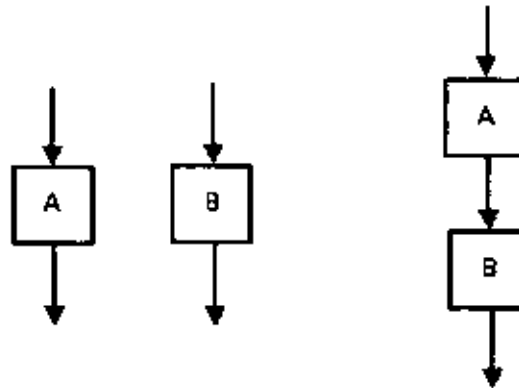

(A) 19 (B) 21 (C) 20 (D) 10

Q.22 What is the appropriate pairing of items in the two columns listing various activities encountered in a software life cycle?

- P. Requirements Capture
- Q. Design
- R. Implementation
- S. Maintenance

- 1. Module Development and Integration
- 2. Domain Analysis
- 3. Structural and Behavioral Modeling
- 4. Performance Tuning

(A) P-3 Q-2 R-4 S-1 (B) P-2 Q-3 R-1 S-4 (C) P-3 Q-2 R-1 S-4 (D) P-2 Q-3 R-4 S-1

Q.23 Consider the methods used by processes P1 and P2 for accessing their critical sections whenever needed, as given below. The initial values of shared boolean variables S1 and S2 are randomly assigned.

Method used by P1	Method used by P2
<pre>while (S1 == S2); Critical Section S1 = S2;</pre>	<pre>while (S1 != S2); Critical Section S2 = not(S1);</pre>

Which one of the following statements describes the properties achieved?

- (A) Mutual exclusion but not progress
- (B) Progress but not mutual exclusion
- (C) Neither mutual exclusion nor progress
- (D) Both mutual exclusion and progress

Q.24 A system uses FIFO policy for page replacement. It has 4 page frames with no pages loaded to begin with. The system first accesses 100 distinct pages in some order and then accesses the same 100 pages but now in the reverse order. How many page faults will occur?

(A) 196 (B) 192 (C) 197 (D) 195

Q.25 Which of the following statements are true?

- I. Shortest remaining time first scheduling may cause starvation
- II. Preemptive scheduling may cause starvation
- III. Round robin is better than FCFS in terms of response time

(A) I only (B) I and III only (C) II and III only (D) I, II and III

Q.26 – Q.55 carry two marks each.

Q.26 Consider a company that assembles computers. The probability of a faulty assembly of any computer is p . The company therefore subjects each computer to a testing process. This testing process gives the correct result for any computer with a probability of q . What is the probability of a computer being declared faulty?

(A) $pq+(1-p)(1-q)$ (B) $(1-q)p$ (C) $(1-p)q$ (D) pq

Q.27 What is the probability that a divisor of 10^{99} is a multiple of 10^{96} ?

(A) $1/625$ (B) $4/625$ (C) $12/625$ (D) $16/625$

Q.28 The degree sequence of a simple graph is the sequence of the degrees of the nodes in the graph in decreasing order. Which of the following sequences can not be the degree sequence of any graph?

- I. 7, 6, 5, 4, 4, 3, 2, 1
- II. 6, 6, 6, 6, 3, 3, 2, 2
- III. 7, 6, 6, 4, 4, 3, 2, 2
- IV. 8, 7, 7, 6, 4, 2, 1, 1

(A) I and II (B) III and IV (C) IV only (D) II and IV

Q.29 Consider the following matrix

$$A = \begin{bmatrix} 2 & 3 \\ x & y \end{bmatrix}$$

If the eigenvalues of A are 4 and 8, then

(A) $x = 4, y = 10$ (B) $x = 5, y = 8$ (C) $x = -3, y = 9$ (D) $x = -4, y = 10$

Q.30 Suppose the predicate $F(x, y, t)$ is used to represent the statement that person x can fool person y at time t . Which one of the statements below expresses best the meaning of the formula $\forall x \exists y \exists t (\neg F(x, y, t))$?

- (A) Everyone can fool some person at some time.
- (B) No one can fool everyone all the time.
- (C) Everyone cannot fool some person all the time.
- (D) No one can fool some person at some time.

- Q.31 What is the boolean expression for the output f of the combinational logic circuit of NOR gates given below?

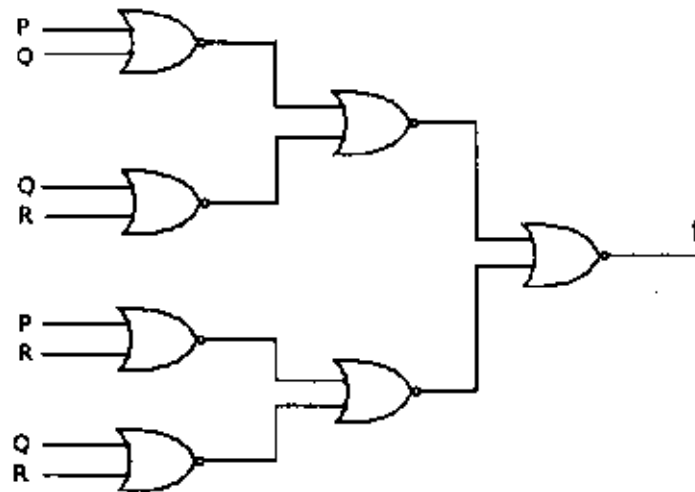

- (A) $\overline{Q+R}$ (B) $\overline{P+Q}$ (C) $\overline{P+R}$ (D) $\overline{P+Q+R}$
- Q.32 In the sequential circuit shown below, if the initial value of the output Q_1Q_0 is 00, what are the next four values of Q_1Q_0 ?

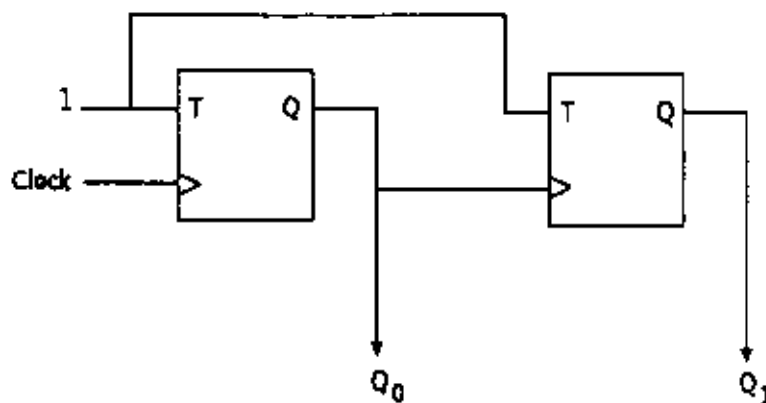

- (A) 11,10,01,00 (B) 10,11,01,00 (C) 10,00,01,11 (D) 11,10,00,01

- Q.33 A 5-stage pipelined processor has Instruction Fetch (IF), Instruction Decode (ID), Operand Fetch (OF), Perform Operation (PO) and Write Operand (WO) stages. The IF, ID, OF and WO stages take 1 clock cycle each for any instruction. The PO stage takes 1 clock cycle for ADD and SUB instructions, 3 clock cycles for MUL instruction, and 6 clock cycles for DIV instruction respectively. Operand forwarding is used in the pipeline. What is the number of clock cycles needed to execute the following sequence of instructions?

Instruction	Meaning of instruction
I_0 : MUL R_7, R_0, R_1	$R_7 \leftarrow R_0 * R_1$
I_1 : DIV R_5, R_3, R_4	$R_5 \leftarrow R_3 / R_4$
I_2 : ADD R_2, R_5, R_2	$R_2 \leftarrow R_5 + R_2$
I_3 : SUB R_3, R_2, R_6	$R_3 \leftarrow R_2 - R_6$

- (A) 13 (B) 15 (C) 17 (D) 19
- Q.34 The weight of a sequence a_0, a_1, \dots, a_{n-1} of real numbers is defined as $a_0 + a_1/2 + \dots + a_{n-1}/2^{n-1}$. A subsequence of a sequence is obtained by deleting some elements from the sequence, keeping the order of the remaining elements the same. Let X denote the maximum possible weight of a subsequence of a_0, a_1, \dots, a_{n-1} and Y the maximum possible weight of a subsequence of a_1, a_2, \dots, a_{n-1} . Then X is equal to

- (A) $\max(Y, a_0 + Y)$ (B) $\max(Y, a_0 + Y/2)$ (C) $\max(Y, a_0 + 2Y)$ (D) $a_0 + Y/2$
- Q.35 What is the value printed by the following C program?

```
#include <stdio.h>

int f(int *a, int n)
{
    if (n <= 0) return 0;
    else if (*a % 2 == 0) return *a + f(a+1, n-1);
    else return *a - f(a+1, n-1);
}

int main( )
{
    int a[] = {12, 7, 13, 4, 11, 6};
    printf("%d", f(a, 6));
    return 0;
}
```

- (A) -9 (B) 5 (C) 15 (D) 19

- Q.36 The following C function takes a singly-linked list as input argument. It modifies the list by moving the last element to the front of the list and returns the modified list. Some part of the code is left blank.

```
typedef struct node {
    int value;
    struct node *next;
} Node;

Node *move_to_front(Node *head) {
    Node *p, *q;
    if ((head == NULL) || (head->next == NULL)) return head;
    q = NULL; p = head;
    while (p->next != NULL) {
        q = p;
        p = p->next;
    }
    _____
    return head;
}
```

Choose the correct alternative to replace the blank line.

- (A) $q = \text{NULL}; p \rightarrow \text{next} = \text{head}; \text{head} = p;$
 (B) $q \rightarrow \text{next} = \text{NULL}; \text{head} = p; p \rightarrow \text{next} = \text{head};$
 (C) $\text{head} = p; p \rightarrow \text{next} = q; q \rightarrow \text{next} = \text{NULL};$
 (D) $q \rightarrow \text{next} = \text{NULL}; p \rightarrow \text{next} = \text{head}; \text{head} = p;$
- Q.37 The program below uses six temporary variables a, b, c, d, e, f .

```
a = 1
b = 10
c = 20
d = a + b
e = c + d
f = c + e
b = c + e
e = b + f
d = 5 + e
return d + f
```

Assuming that all operations take their operands from registers, what is the minimum number of registers needed to execute this program without spilling?

- (A) 2 (B) 3 (C) 4 (D) 6
- Q.38 The grammar $S \rightarrow aSa \mid bS \mid c$ is
- (A) LL(1) but not LR(1) (B) LR(1) but not LL(1)
 (C) Both LL(1) and LR(1) (D) Neither LL(1) nor LR(1)
- Q.39 Let $L = \{ w \in \{0, 1\}^* \mid w \text{ has even number of 1s} \}$, i.e. L is the set of all bit strings with even number of 1s. Which one of the regular expressions below represents L ?
- (A) $(0^*10^*)^*$ (B) $0^*(10^*10^*)^*$ (C) $0^*(10^*1)^*0^*$ (D) $0^*1(10^*1)^*10^*$

Q.40 Consider the languages $L1 = \{0^i1^j \mid i \neq j\}$, $L2 = \{0^i1^j \mid i = j\}$, $L3 = \{0^i1^j \mid i = 2j+1\}$, $L4 = \{0^i1^j \mid i \neq 2j\}$. Which one of the following statements is true?

- (A) Only $L2$ is context free.
 (B) Only $L2$ and $L3$ are context free.
 (C) Only $L1$ and $L2$ are context free.
 (D) All are context free.

Q.41 Let w be any string of length n in $\{0,1\}^*$. Let L be the set of all substrings of w . What is the minimum number of states in a non-deterministic finite automaton that accepts L ?

- (A) $n-1$ (B) n (C) $n+1$ (D) 2^{n-1}

Q.42 Consider the following schedule for transactions T1, T2 and T3:

<u>T1</u>	<u>T2</u>	<u>T3</u>
Read (X)		
	Read (Y)	
		Read (Y)
	Write (Y)	
Write (X)		
		Write (X)
	Read (X)	
	Write (X)	

Which one of the schedules below is the correct serialization of the above?

- (A) T1 \rightarrow T3 \rightarrow T2 (B) T2 \rightarrow T1 \rightarrow T3
 (C) T2 \rightarrow T3 \rightarrow T1 (D) T3 \rightarrow T1 \rightarrow T2

Q.43 The following functional dependencies hold for relations $R(A, B, C)$ and $S(B, D, E)$:

$B \rightarrow A$,
 $A \rightarrow C$

The relation R contains 200 tuples and the relation S contains 100 tuples. What is the maximum number of tuples possible in the natural join $R \bowtie S$?

- (A) 100 (B) 200 (C) 300 (D) 2000

Q.44 The following program is to be tested for statement coverage:

```
begin
  if (a == b) {S1; exit;}
  else if (c == d) {S2;}
    else {S3; exit;}
  S4;
end
```

The test cases T1, T2, T3 and T4 given below are expressed in terms of the properties satisfied by the values of variables a , b , c and d . The exact values are not given.

T1: a , b , c and d are all equal
 T2: a , b , c and d are all distinct
 T3: $a = b$ and $c \neq d$
 T4: $a \neq b$ and $c = d$

Which of the test suites given below ensures coverage of statements S1, S2, S3 and S4?

- (A) T1, T2, T3 (B) T2, T4 (C) T3, T4 (D) T1, T2, T4
- Q.45 The following program consists of 3 concurrent processes and 3 binary semaphores. The semaphores are initialized as $S_0=1$, $S_1=0$, $S_2=0$.

Process P0	Process P1	Process P2
<pre>while (true) { wait (S0); print '0'; release (S1); release (S2); }</pre>	<pre>wait (S1); release (S0);</pre>	<pre>wait (S2); release (S0);</pre>

How many times will process P0 print '0'?

- (A) At least twice (B) Exactly twice (C) Exactly thrice (D) Exactly once
- Q.46 A system has n resources R_0, R_{n-1} , and k processes P_0, \dots, P_{k-1} . The implementation of the resource request logic of each process P_i is as follows:
- ```
if (i%2==0) {
 if (i<n) request R_i ;
 if (i+2 < n) request R_{i+2} ;
}
else {
 if (i<n) request R_{n-i} ;
 if (i-2<n) request R_{n-i-2} ;
}
```

In which one of the following situations is a deadlock possible?

- (A)  $n = 40$ ,  $k = 26$       (B)  $n = 21$ ,  $k = 12$       (C)  $n = 20$ ,  $k = 10$       (D)  $n = 41$ ,  $k = 19$
- Q.47 Suppose computers A and B have IP addresses 10.105.1.113 and 10.105.1.91 respectively and they both use the same netmask N. Which of the values of N given below should not be used if A and B should belong to the same network?
- (A) 255.255.255.0      (B) 255.255.255.128      (C) 255.255.255.192      (D) 255.255.255.224

## Common Data Questions

### Common Data for Questions 48 and 49:

A computer system has an L1 cache, an L2 cache, and a main memory unit connected as shown below. The block size in L1 cache is 4 words. The block size in L2 cache is 16 words. The memory access times are 2 nanoseconds, 20 nanoseconds and 200 nanoseconds for L1 cache, L2 cache and main memory unit respectively.

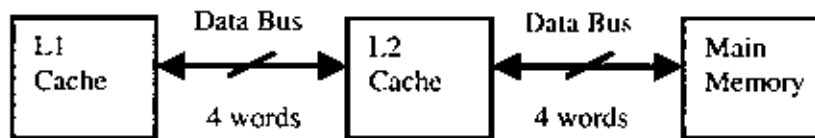

- Q.48 When there is a miss in L1 cache and a hit in L2 cache, a block is transferred from L2 cache to L1 cache. What is the time taken for this transfer?
- (A) 2 nanoseconds    (B) 20 nanoseconds    (C) 22 nanoseconds    (D) 88 nanoseconds
- Q.49 When there is a miss in both L1 cache and L2 cache, first a block is transferred from main memory to L2 cache, and then a block is transferred from L2 cache to L1 cache. What is the total time taken for these transfers?
- (A) 222 nanoseconds    (B) 888 nanoseconds  
(C) 902 nanoseconds    (D) 968 nanoseconds

### Common Data for Questions 50 and 51:

Consider a complete undirected graph with vertex set  $\{0,1,2,3,4\}$ . Entry  $W_{ij}$  in the matrix  $W$  below is the weight of the edge  $\{i,j\}$ .

$$W = \begin{pmatrix} 0 & 1 & 8 & 1 & 4 \\ 1 & 0 & 12 & 4 & 9 \\ 8 & 12 & 0 & 7 & 3 \\ 1 & 4 & 7 & 0 & 2 \\ 4 & 9 & 3 & 2 & 0 \end{pmatrix}$$

- Q.50 What is the minimum possible weight of a spanning tree  $T$  in this graph such that vertex 0 is a leaf node in the tree  $T$ ?
- (A) 7    (B) 8    (C) 9    (D) 10
- Q.51 What is the minimum possible weight of a path  $P$  from vertex 1 to vertex 2 in this graph such that  $P$  contains at most 3 edges?
- (A) 7    (B) 8    (C) 9    (D) 10

**Linked Answer Questions****Statement for Linked Answer Questions 52 and 53:**

A hash table of length 10 uses open addressing with hash function  $h(k) = k \bmod 10$ , and linear probing. After inserting 6 values into an empty hash table, the table is as shown below.

|   |    |
|---|----|
| 0 |    |
| 1 |    |
| 2 | 42 |
| 3 | 23 |
| 4 | 34 |
| 5 | 52 |
| 6 | 46 |
| 7 | 33 |
| 8 |    |
| 9 |    |

- Q.52 Which one of the following choices gives a possible order in which the key values could have been inserted in the table?
- (A) 46, 42, 34, 52, 23, 33  
(B) 34, 42, 23, 52, 33, 46  
(C) 46, 34, 42, 23, 52, 33  
(D) 42, 46, 33, 23, 34, 52
- Q.53 How many different insertion sequences of the key values using the same hash function and linear probing will result in the hash table shown above?
- (A) 10                      (B) 20                      (C) 30                      (D) 40

**Statement for Linked Answer Questions 54 and 55:**

Consider a network with 6 routers R1 to R6 connected with links having weights as shown in the following diagram.

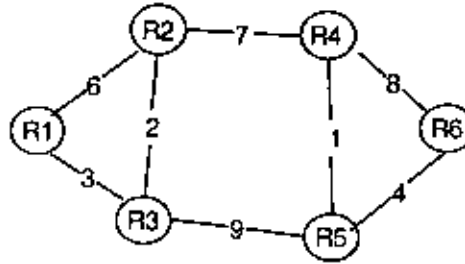

- Q.54** All the routers use the distance vector based routing algorithm to update their routing tables. Each router starts with its routing table initialized to contain an entry for each neighbour with the weight of the respective connecting link. After all the routing tables stabilize, how many links in the network will never be used for carrying any data?
- (A) 4                      (B) 3                      (C) 2                      (D) 1
- Q.55** Suppose the weights of all unused links in the previous question are changed to 2 and the distance vector algorithm is used again until all routing tables stabilize. How many links will now remain unused?
- (A) 0                      (B) 1                      (C) 2                      (D) 3

**General Aptitude (GA) Questions****Q.56 – Q.60 carry one mark each.**

Q.56 Choose the most appropriate word from the options given below to complete the following sentence:

**His rather casual remarks on politics \_\_\_\_\_ his lack of seriousness about the subject.**

- (A) masked
- (B) belied
- (C) betrayed
- (D) suppressed

Q.57 Which of the following options is the closest in meaning to the word below:

**Circuitous**

- (A) cyclic
- (B) indirect
- (C) confusing
- (D) crooked

Q.58 Choose the most appropriate word from the options given below to complete the following sentence:

**If we manage to \_\_\_\_\_ our natural resources, we would leave a better planet for our children.**

- (A) uphold
- (B) restrain
- (C) cherish
- (D) conserve

Q.59 25 persons are in a room. 15 of them play hockey, 17 of them play football and 10 of them play both hockey and football. Then the number of persons playing neither hockey nor football is:

- (A) 2                                      (B) 17                                      (C) 13                                      (D) 3

Q.60 The question below consists of a pair of related words followed by four pairs of words. Select the pair that best expresses the relation in the original pair.

**Unemployed : Worker**

- (A) fallow : land
- (B) unaware : sleeper
- (C) wit : jester
- (D) renovated : house

**Q.61 – Q.65 carry two marks each.**

Q.61 If  $137 + 276 = 435$  how much is  $731 + 672$ ?

- (A) 534                                      (B) 1403                                      (C) 1623                                      (D) 1513

- Q.62 Hari (H), Gita (G), Irfan (I) and Saira (S) are siblings (i.e. brothers and sisters). All were born on 1<sup>st</sup> January. The age difference between any two successive siblings (that is born one after another) is less than 3 years. Given the following facts:
- Hari's age + Gita's age > Irfan's age + Saira's age.
  - The age difference between Gita and Saira is 1 year. However, Gita is not the oldest and Saira is not the youngest.
  - There are no twins.
- In what order were they born (oldest first)?
- (A) HSIQ                      (B) SGHI                      (C) IGSB                      (D) IHSG
- Q.63 **Modern warfare has changed from large scale clashes of armies to suppression of civilian populations. Chemical agents that do their work silently appear to be suited to such warfare; and regrettably, there exist people in military establishments who think that chemical agents are useful tools for their cause.**
- Which of the following statements best sums up the meaning of the above passage:*
- (A) Modern warfare has resulted in civil strife.  
(B) Chemical agents are useful in modern warfare.  
(C) Use of chemical agents in warfare would be undesirable.  
(D) People in military establishments like to use chemical agents in war.
- Q.64 5 skilled workers can build a wall in 20 days; 8 semi-skilled workers can build a wall in 25 days; 10 unskilled workers can build a wall in 30 days. If a team has 2 skilled, 6 semi-skilled and 5 unskilled workers, how long will it take to build the wall?
- (A) 20 days                      (B) 18 days                      (C) 16 days                      (D) 15 days
- Q.65 Given digits 2, 2, 3, 3, 3, 4, 4, 4, 4 how many distinct 4 digit numbers greater than 3000 can be formed?
- (A) 50                              (B) 51                              (C) 52                              (D) 54

**END OF THE QUESTION PAPER**



---

## Space for Rough Work

---

## Space for Rough Work

---

## Space for Rough Work

---

## Space for Rough Work

---

## Space for Rough Work

---

## Space for Rough Work

---

## Space for Rough Work

---

## Space for Rough Work

SEAL