

General Aptitude

Q. No. 1 – 5 Carry One Mark Each

1. Choose the word most similar in meaning to the given word:

Educe

- (A) Exert (B) Educate (C) Extract (D) Extend

Answer: (C)

2. If $\log_x (5/7) = -1/3$, then the value of x is

- (A) 343/125 (B) 125/343 (C) -25/49 (D) -49/25

Answer: (A)

Exp: $\frac{5}{7} = x^{-1/3} \Rightarrow \frac{7}{5} = x^{1/3} \Rightarrow \left(\frac{7}{5}\right)^3 \Rightarrow x = 2.74$

3. Operators \square, \diamond and \rightarrow are defined by: $a \square b = \frac{a-b}{a+b}$; $a \diamond b = \frac{a+b}{a-b}$; $a \rightarrow b = ab$. Find the value

$(66 \square 6) \rightarrow (66 \diamond 6)$.

- (A) -2 (B) -1 (C) 1 (D) 2

Answer: (C)

Exp: $66 \square 6 = \frac{66-6}{66+6} = \frac{60}{72} = \frac{5}{6}$

$66 \diamond 6 = \frac{66+6}{66-6} = \frac{72}{60} = \frac{6}{5}$

$(66 \square 6) \rightarrow (66 \diamond 6) = \frac{5}{6} \times \frac{6}{5} = 1$

4. Choose the most appropriate word from the options given below to complete the following sentence.

The principal presented the chief guest with a _____, as token of appreciation.

- (A) momento (B) memento (C) momentum (D) moment

Answer: (B)

5. Choose the appropriate word/phrase, out of the four options given below, to complete the following sentence:

Frogs _____.

- (A) Croak (B) Roar (C) Hiss (D) Patter

Answer: (A)

Exp: Frogs make 'croak' sound.

Q. No. 6 – 10 Carry Two Marks Each

6. A cube of side 3 units is formed using a set of smaller cubes of side 1 unit. Find the proportion of the number of faces of the smaller cubes visible to those which are NOT visible.

- (A) 1 : 4 (B) 1 : 3 (C) 1 : 2 (D) 2 : 3

Answer: (C)

Exp:

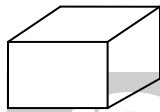
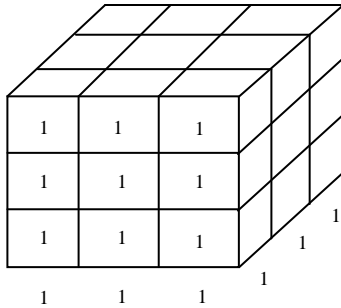

Number of faces per cube = 6

Total number of cubes = $9 \times 3 = 27$

∴ Total number of faces = $27 \times 6 = 162$

∴ Total number of non visible faces = $162 - 54 = 108$

∴ $\frac{\text{Number of visible faces}}{\text{Number of non visible faces}} = \frac{54}{108} = \frac{1}{2}$

7. Fill in the missing value

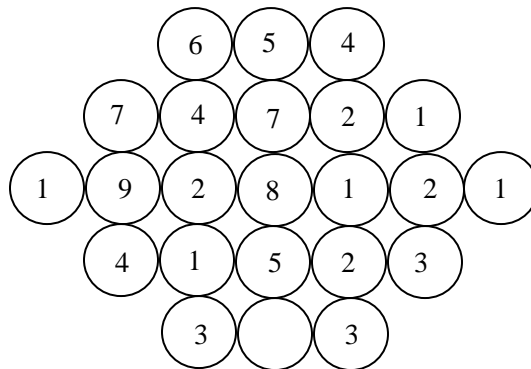

Answer: 3

Exp: Middle number is the average of the numbers on both sides.

Average of 6 and 4 is 5

Average of (7+4) and (2+1) is 7

Average of $(1+9+2)$ and $(1+2+1)$ is 8

Average of $(4+1)$ and $(2+3)$ is 5

Therefore, Average of (3) and (3) is 3

8. Humpty Dumpty sits on a wall every day while having lunch. The wall sometimes breaks. A person sitting on the wall falls if the wall breaks.

Which one of the statements below is logically valid and can be inferred from the above sentences?

- (A) Humpty Dumpty always falls while having lunch
- (B) Humpty Dumpty does not fall sometimes while having lunch
- (C) Humpty Dumpty never falls during dinner
- (D) When Humpty Dumpty does not sit on the wall, the wall does not break

Answer: (B)

9. The following question presents a sentence, part of which is underlined. Beneath the sentence you find four ways of phrasing the underline part. Following the requirements of the standard written English, select the answer that produces the most effective sentence.

Tuberculosis, together with its effects, ranks one of the leading causes of death in India.

- (A) ranks as one of the leading causes of death
- (B) rank as one of the leading causes of death
- (C) has the rank of one of the leading causes of death
- (D) are one of the leading causes of death

Answer: (A)

10. Read the following paragraph and choose the correct statement.

Climate change has reduced human security and threatened human well being. An ignored reality of human progress is that human security largely depends upon environmental security. But on the contrary, human progress seems contradictory to environmental security. To keep up both at the required level is a challenge to be addressed by one and all. One of the ways to curb the climate change may be suitable scientific innovations, while the other may be the Gandhian perspective on small scale progress with focus on sustainability.

- (A) Human progress and security are positively associated with environmental security.
- (B) Human progress is contradictory to environmental security.
- (C) Human security is contradictory to environmental security.
- (D) Human progress depends upon environmental security.

Answer: (B)

Electronics and Communication Engineering

Q. No. 1 – 25 Carry One Mark Each

1. A region of negative differential resistance is observed in the current voltage characteristics of a silicon PN junction if
- (A) Both the P-region and the N-region are heavily doped
 - (B) The N-region is heavily doped compared to the P-region
 - (C) The P-region is heavily doped compared to the N-region
 - (D) An intrinsic silicon region is inserted between the P-region and the N-region

Answer: (A)

2. A silicon sample is uniformly doped with donor type impurities with a concentration of $10^{16} / \text{cm}^3$. The electron and hole mobilities in the sample are $1200 \text{cm}^2 / \text{V-s}$ and $400 \text{cm}^2 / \text{V-s}$ respectively. Assume complete ionization of impurities. The charge of an electron is $1.6 \times 10^{-19} \text{C}$. The resistivity of the sample (in $\Omega\text{-cm}$) is _____.

Answer: 0.52

Exp:
$$P = \frac{1}{\sigma_N} = \frac{1}{N_D q \mu_n}$$

$$= \frac{1}{10^{16} \times 1.6 \times 10^{-19} \times 1200}$$

$$= 0.52 \Omega\text{-cm}$$

3. A unity negative feedback system has the open-loop transfer function $G(s) = \frac{K}{s(s+1)(s+3)}$. The value of the gain K (>0) at which the root locus crosses the imaginary axis is _____.

Answer: 12

Exp:
$$1 + \frac{k}{s(s+1)(s+3)} = 0$$

$$s^3 + 4s^2 + 3s + k = 0$$

By using Routh Table, s^1 row should be zero. For poles to be on imaginary axis

$$\frac{12-k}{4} = 0 ; k \text{ should be } 12.$$

4. Suppose A and B are two independent events with probabilities $P(A) \neq 0$ and $P(B) \neq 0$. Let \bar{A} and \bar{B} be their complements. Which one of the following statements is FALSE?

- (A) $P(A \cap B) = P(A)P(B)$
- (B) $P(A \setminus B) = P(A)$
- (C) $P(A \cup B) = P(A) + P(B)$
- (D) $P(\bar{A} \cap \bar{B}) = P(\bar{A})P(\bar{B})$

Answer: (C)

Exp: We know that A and B are independent then $P(A \cap B) = P(A) P(B)$

A and B are independent then $P(A/B) = P(A)$ and $P(B/A) = P(B)$

Also if A and B are independent then \bar{A} and \bar{B} are also independent

i.e., $P(\bar{A} \cap \bar{B}) = P(\bar{A})P(\bar{B})$

\therefore (A), (B), (D) are correct

(C) is false

Since $P(A \cup B) = P(A) + P(B) - P(A \cap B)$
 $= P(A) + P(B) - P(A)P(B)$

5. The waveform of a periodic signal $x(t)$ is shown in the figure.

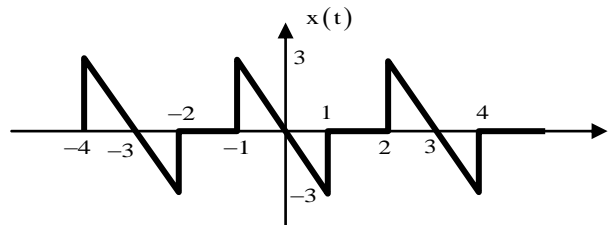

A signal $g(t)$ is defined by $g(t) = x\left(\frac{t-1}{2}\right)$. The average power of $g(t)$ is

Answer: 1.5

Exp: $g(t) = x\left(\frac{t-1}{2}\right)$

The average power of $x(t)$ and $g(t)$ is same because the signal $g(t)$ is scaled and shifted version of $x(t)$.

$$\text{Power of } x(t) = \lim_{T \rightarrow \infty} \frac{1}{4} \int_{-1}^1 (-3t)^2 dt$$

$$= \lim_{T \rightarrow \infty} \frac{9}{4} \left[\frac{t^3}{3} \right]_{-1}^1 = \frac{9}{4} \times \frac{2}{2} = \frac{3}{2}$$

$$\therefore \text{Power of } g(t) = \frac{3}{2}$$

6. In the network shown in the figure, all resistors are identical with $R = 300\Omega$. The resistance R_{ab} (in Ω) of the network is _____.

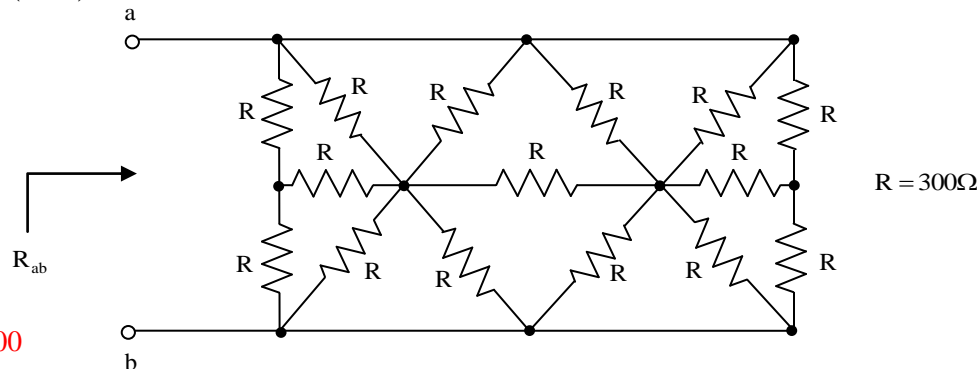

Answer: 100

Exp:

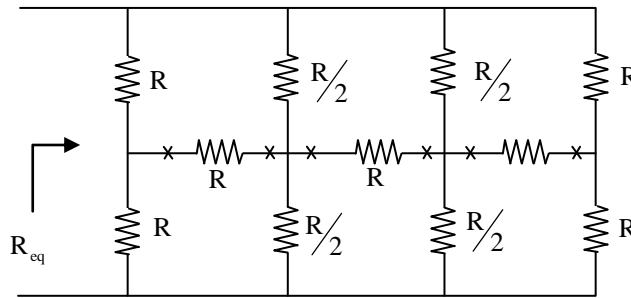

By bridge condition

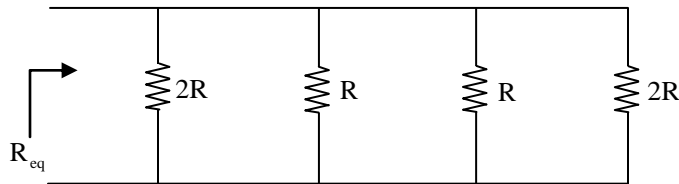

$$R_{eq} = \frac{R}{3} = 100\Omega$$

7. Consider a system of linear equations:

$$x - 2y + 3z = -1$$

$$x - 3y + 4z = 1 \text{ and}$$

$$-2x + 4y - 6z = k.$$

The value of k for which the system has infinitely many solutions is _____.

Answer: 2

Exp: $x - 2y + 3z = -1$

$$x - 3y + 4z = 1$$

$$-2x + 4y - 6z = k$$

$$\text{Augmented matrix (A/B)} = \begin{bmatrix} 1 & -2 & 3 & -1 \\ 1 & -3 & 4 & 1 \\ -2 & 4 & -6 & K \end{bmatrix}$$

$$R_2 \rightarrow R_2 - R_1, R_3 \rightarrow R_3 + 2R_1$$

$$\begin{bmatrix} 1 & -2 & 3 & -1 \\ 0 & -1 & 1 & 2 \\ 0 & 0 & 0 & K-2 \end{bmatrix}$$

The system will have infinitely many solutions if $p(A/B) = p(A) = r < \text{number of variables}$

$$\Rightarrow k - 2 = 0$$

$$\Rightarrow k = 2$$

$$u_y = 0 \text{ and } v_y = -1$$

$\Rightarrow u_x \neq v_y$ i.e., C-R equations not satisfied

$\therefore \bar{z}$ is not analytic

(A) $z = 1$ is a simple pole

$$\therefore \text{Residue} \left(\frac{z}{z^2 - 1} \right) \text{ at } z = 1 \text{ is } \lim_{z \rightarrow 1} (z-1) \cdot \frac{z}{z^2 - 1} = \lim_{z \rightarrow 1} \frac{z}{z+1} = \frac{1}{2}$$

(B) Since z^2 is analytic everywhere

$$\therefore \text{Using Cauchy's integral theorem, } \oint_C z^2 dz = 0$$

10. Consider the signal $s(t) = m(t)\cos(2\pi f_c t) + \hat{m}(t)(2\pi f_c t)$ where $\hat{m}(t)$ denotes the Hilbert transform of $m(t)$ and the bandwidth of $m(t)$ is very small compared to f_c . The signal $s(t)$ is a

- (A) high-pass signal
- (B) low-pass signal
- (C) band-pass signal
- (D) double sideband suppressed carrier signal

Answer: (C)

Exp: Given $s(t)$ is the equation for single side band modulation (lower side band). Thus it is a Band pass signal.

11. For the circuit with ideal diodes shown in the figure, the shape of the output (v_{out}) for the given sine wave input (v_{in}) will be

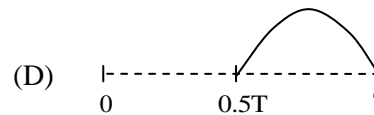
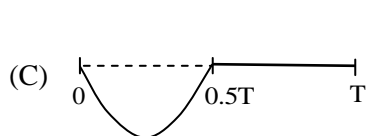
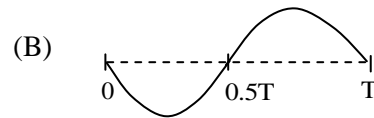
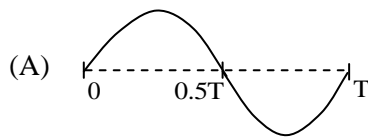
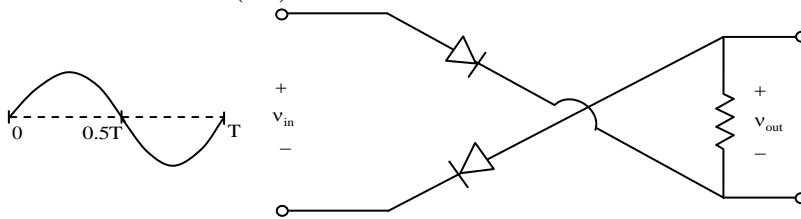

Answer: (C)

Exp: The circuit can be re drawn as

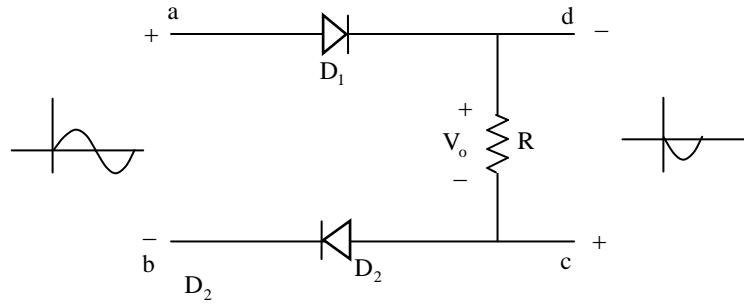

During positive pulse, both diodes are forward biased. So output pulse of +ve polarity is produced. As polarity at 'd' and 'c' is given opposite to input terminals, hence +ve pulse is inverted. During negative pulse, both diodes are reverse biased. So, $V_o = 0V$

12. The result of the convolution $x(-t) * \delta(-t - t_0)$ is

- (A) $x(t + t_0)$ (B) $x(t - t_0)$ (C) $x(-t + t_0)$ (D) $x(-t - t_0)$

Answer: (D)

Exp: $x(-t) * \delta(-t - t_0) = x(-t) * \delta(t + t_0)$

$$= x(-t(t + t_0))$$

$$= x(-t - t_0)$$

13. The value of p such that the vector $\begin{bmatrix} 1 \\ 2 \\ 3 \end{bmatrix}$ is an eigenvector of the matrix $\begin{bmatrix} 4 & 1 & 2 \\ p & 2 & 1 \\ 14 & -4 & 10 \end{bmatrix}$ is

_____.

Answer: 17

Exp: $AX = \lambda X \Rightarrow \begin{bmatrix} 4 & 1 & 2 \\ p & 2 & 1 \\ 14 & -4 & 10 \end{bmatrix} \begin{bmatrix} 1 \\ 2 \\ 3 \end{bmatrix} = \lambda \begin{bmatrix} 1 \\ 2 \\ 3 \end{bmatrix}$

$$\Rightarrow \begin{bmatrix} 12 \\ p+7 \\ 36 \end{bmatrix} = \begin{bmatrix} \lambda \\ 2\lambda \\ 3\lambda \end{bmatrix} \Rightarrow \lambda = 12 \text{ ----- (1)}$$

$$2\lambda = p + 7 \text{ ----- (2)}$$

and $3\lambda = 36$ i.e., $\lambda = 12$

\therefore Equation (2) gives $p + 7 = 24 \Rightarrow p = 17$

14. In the given circuit, the values of V_1 and V_2 respectively are

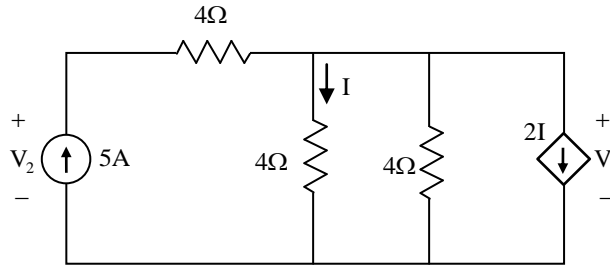

- (A) 5V, 25V (B) 10V, 30V (C) 15V, 35V (D) 0V, 20V

Answer: (A)

Exp: By nodal analysis

$$-5 + I + I + 2I = 0$$

$$4I = 5$$

$$I = \frac{5}{4} \text{ A}$$

$$V_1 = 4I = 5 \text{ volts}$$

$$V_2 = 4(5) + V_1 \\ = 20 + V_1 = 25 \text{ volts}$$

15. In an 8085 microprocessor, the shift registers which store the result of an addition and the overflow bit are, respectively

- (A) B and F (B) A and F (C) H and F (D) A and C

Answer: (B)

Exp: In an 8085 microprocessor, after performing the addition, result is stored in accumulator and if any carry (overflow bit) is generated it updates flags.

16. Negative feedback in a closed-loop control system DOES NOT

- (A) reduce the overall gain (B) reduce bandwidth
(C) improve disturbance rejection (D) reduce sensitivity to parameter variation

Answer: (B)

Exp: Negative feedback in a closed loop

- (i) Increases bandwidth
(ii) Reduces gain
(iii) Improve disturbance rejection

17. A 16 Kb (=16,384 bit) memory array is designed as a square with an aspect ratio of one (number of rows is equal to the number of columns). The minimum number of address lines needed for the row decoder is _____.

Answer: 7

Exp: Generally the structure of a memory chip = Number of Row \times Number of column
= $M \times N$

→ The number of address line required for row decoder is n where $M = 2^n$ or
 $n = \log_2 M$

→ As per information given in question : $M = N$

$$\text{So } M \times N = M \times M = M^2 = 16k = 2^4 \times 2^{10}$$

$$\Rightarrow M^2 = 2^{14}$$

$$\Rightarrow M = 128$$

→ $n = \log_2 128 = 7$

18. A function $f(x) = 1 - x^2 + x^3$ is defined in the closed interval $[-1, 1]$. The value of x, in the open interval $(-1, 1)$ for which the mean value theorem is satisfied, is

(A) -1/2 (B) -1/3 (C) 1/3 (D) 1/2

Answer: (B)

Exp: By Lagrange's mean value theorem

$$f'(x) = \frac{f(1) - f(-1)}{1 - (-1)} = \frac{2}{2} = 1$$

$$-2x + 3x^2 = 1$$

$$3x^2 - 2x - 1 = 0$$

$$\text{So } x = 1, -1/3$$

$x = -1/3$ only lies in $(-1, 1)$

19. The electric field component of a plane wave traveling in a lossless dielectric medium is given by $\vec{E}(z, t) = \hat{a}_y 2 \cos\left(10^8 t - \frac{z}{\sqrt{2}}\right)$ V/m. The wavelength (in m) for the wave is _____.

Answer: 8.885

Exp: $E(z, t) = 2 \cos\left(10^8 t - \frac{z}{\sqrt{2}}\right) \hat{a}_y$

$$\lambda = \frac{2\pi}{\beta} = 2\pi\sqrt{2}$$

$$\lambda = 8.885 \text{ m}$$

20. In the circuit shown, the switch SW is thrown from position A to position B at time $t = 0$. The energy (in μJ) taken from the 3V source to charge the $0.1\mu\text{F}$ capacitor from 0V to 3V is

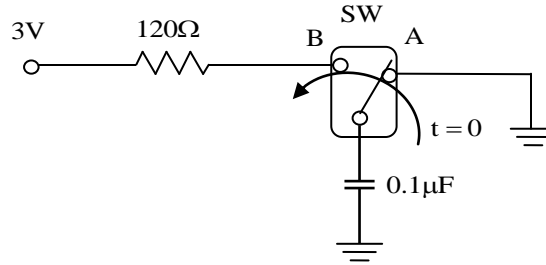

- (A) 0.3 (B) 0.45 (C) 0.9 (D) 3

Answer: (C)

Exp: So the capacitor is initially uncharged i.e. $V_c(0) = 0$

→ The capacitor will be charged to supply voltage 3V when the switch is in position B for ∞ time.

→ So we need to find capacitor voltage

$$V_c(t) = V_c(\infty) + [V_c(0) - V_c(\infty)]e^{-t/\tau}$$

$$= 3 - 3e^{-t/\tau}$$

$$\tau = RC = 120 \times 0.1 \times 10^{-6} = 12 \mu\text{sec}$$

$$i_c = C \frac{dV_c}{dt}$$

$$= (0.1 \times 10^{-6}) \frac{d}{dt} [3 - 3e^{-t/\tau}]$$

$$= \frac{3 \times 0.1}{\tau} e^{-t/\tau} = \frac{0.3}{12} = e^{-t/\tau}$$

→ So instantaneous power of source = $V(t)i(t)$

$$P(t) = (3) \left[\frac{0.3}{12} e^{-t/\tau} \right] = \frac{0.9}{12} e^{-t/\tau}$$

$$\rightarrow E = \int_0^{\infty} P dt$$

$$= \int_0^{\infty} \frac{0.9}{12} e^{-t/\tau} dt$$

$$= (-\tau) \frac{0.9}{12} [e^{-t/\tau}]_0^{\infty} = \tau \left(\frac{0.9}{12} \right)$$

$$= 12 \times 10^{-6} \times \frac{0.9}{12}$$

$$= 0.9 \mu\text{J}$$

21. In the circuit shown below, the Zener diode is ideal and the Zener voltage is 6V. The output voltage V_o (in volts) is _____.

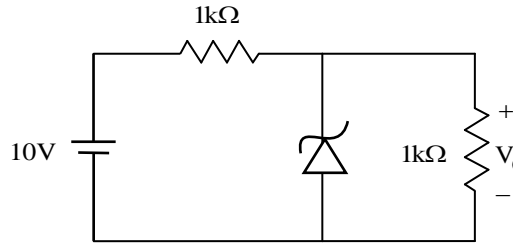

Answer: 5

Exp: Zener is not Breakdown

Hence

$$V_o = 10 \times \frac{1}{2} = 5V$$

22. Consider a four bit D to A converter. The analog value corresponding to digital signals of values 0000 and 0001 are 0V and 0.0625V respectively. The analog value (in Volts) corresponding to the digital signal 1111 is _____.

Answer: 0.9225

Exp: Analog output = [Resolution] \times [Decimal equivalent of Binary]
= (0.0615) (15) = 0.9225V

23. In the circuit shown, at resonance, the amplitude of the sinusoidal voltage (in Volts) across the capacitor is _____.

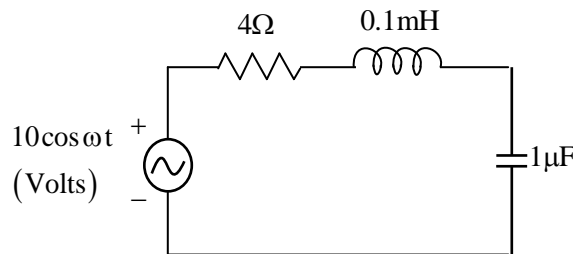

Answer: 25

Exp: $V_c = QV \angle -90^\circ$

$$Q = \frac{\omega_0 L}{R} = \frac{1}{R} \sqrt{\frac{L}{C}} = \frac{10}{4} = 2.5$$

$$V_c = 25 \angle -90^\circ$$

$$|V_c| = 25V$$

24 A sinusoidal signal of 2 kHz frequency is applied to a delta modulator. The sampling rate and step-size Δ of the delta modulator are 20,000 samples per second and 0.1V, respectively. To prevent slope overload, the maximum amplitude of the sinusoidal signal (in Volts) is

- (A) $\frac{1}{2\pi}$ (B) $\frac{1}{\pi}$ (C) $\frac{2}{\pi}$ (D) π

Answer: (A)

Exp: To avoid slope overload,

$$\Delta \cdot T_s \geq \left| \frac{d}{dt} x(t) \right|_{\max}$$

$$x(t) = E_m \sin(2\pi f_m t)$$

$$\left| \frac{d}{dt} x(t) \right|_{\max} = E_m \cdot 2\pi f_m$$

$$0.1 \times 20,000 \geq E_m \cdot 2\pi \cdot 2000$$

$$\Rightarrow E_m \leq \frac{1}{2\pi}$$

25. Consider a straight, infinitely long, current carrying conductor lying on the z-axis. Which one of the following plots (in linear scale) qualitatively represents the dependence of H_ϕ on r , where H_ϕ is the magnitude of the azimuthal component of magnetic field outside the conductor and r is the radial distance from the conductor?

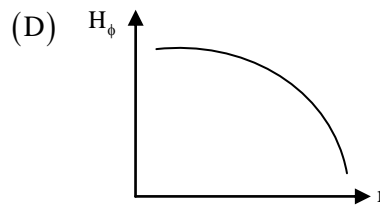
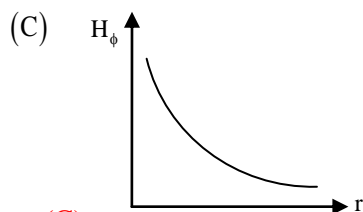
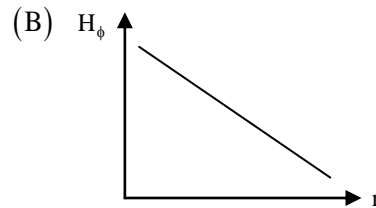
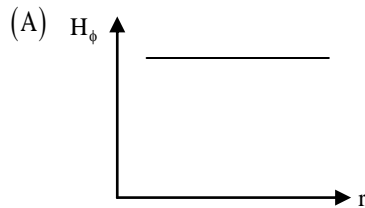

Answer: (C)

Exp: $H_\phi = \frac{I}{2\pi r}$

r is the distance from current element.

$$H_\phi \propto \frac{1}{r}$$

Q. No. 26 – 55 carry Two Marks Each

26. The input X to the Binary Symmetric Channel (BSC) shown in the figure is '1' with probability 0.8. The cross-over probability is 1/7. If the received bit Y = 0, the conditional probability that '1' was transmitted is _____.

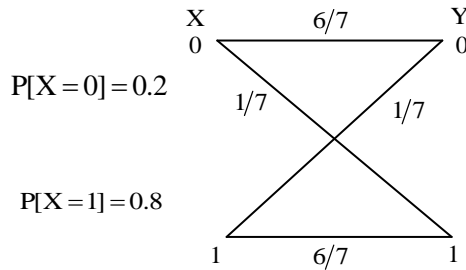

Answer: 0.4

Exp:

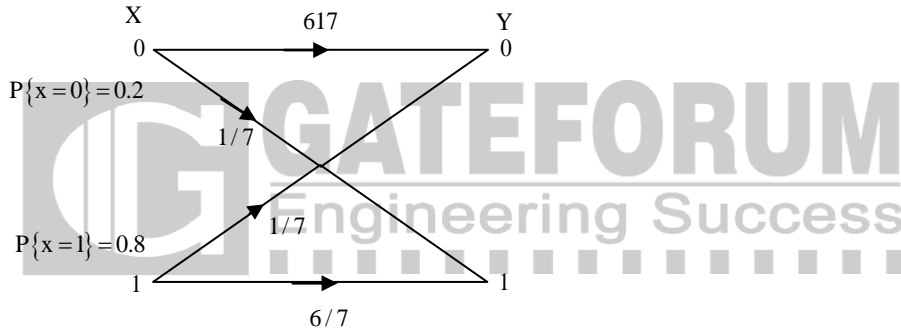

$$P\{x=1/y=0\} = \frac{P\{y=0/x=1\}P\{x=1\}}{P\{y=0\}}$$

$$P\{y=0/x=1\} = \frac{1}{7}$$

$$P\{x=1\} = 0.8$$

$$P\{y=0\} = 0.2 \times \frac{6}{7} + 0.8 \times \frac{1}{7} = \frac{2}{7}$$

$$\Rightarrow P\{x=1/y=0\} = \frac{\frac{1}{7}(0.8)}{\frac{2}{7}} = 0.4$$

27. The transmitted signal in a GSM system is of 200 kHz bandwidth and 8 users share a common bandwidth using TDMA. If at a given time 12 users are talking in a cell, the total bandwidth of the signal received by the base station of the cell will be at least (in kHz)

Answer: 400

Exp: Since GSM requires 200 KHz and only 8 users can use it using TDMA, 9th user needs another 200 KHz.

9th, 10th, 11th, 12th user can use another 200 KHz bandwidth on time share basis.

Thus for 12 user we need 400 KHz bandwidth.

28. For the discrete-time system shown in the figure, the poles of the system transfer function are located at

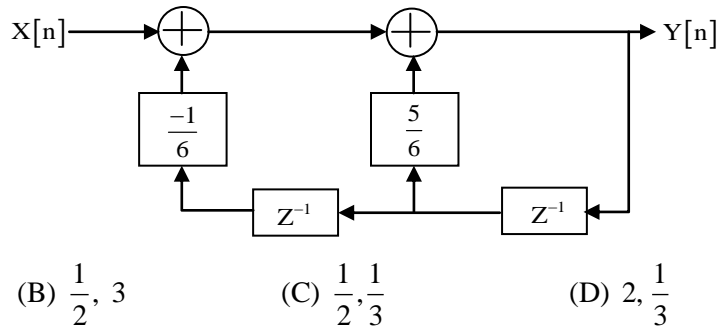

- (A) 2, 3 (B) $\frac{1}{2}, 3$ (C) $\frac{1}{2}, \frac{1}{3}$ (D) $2, \frac{1}{3}$

Answer: (C)

Exp:

$$\frac{Y(z)}{X(z)} = H(z) = \frac{1}{1 - \frac{5}{6}z^{-1} + \frac{z^{-2}}{6}} = \frac{z^2}{z^2 - \frac{5}{6}z + \frac{1}{6}} = \frac{z^2}{\left(z - \frac{1}{2}\right)\left(z - \frac{1}{3}\right)}$$

So, poles are $z = \frac{1}{2}, z = \frac{1}{3}$.

29. The circuit shown in the figure has an ideal opamp. The oscillation frequency and the condition to sustain the oscillations, respectively, are

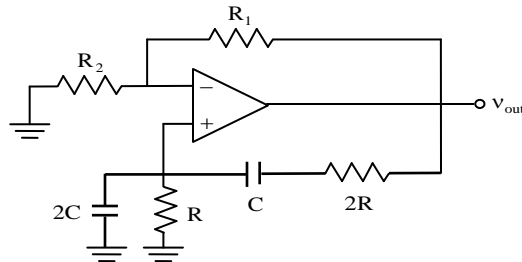

- (A) $\frac{1}{CR}$ and $R_1 = R_2$ (B) $\frac{1}{CR}$ and $R_1 = 4R_2$
 (C) $\frac{1}{2CR}$ and $R_1 = R_2$ (D) $\frac{1}{2CR}$ and $R_1 = 4R_2$

Answer: (D)

Exp: Frequency of Wein bridge oscillator is $\omega_0 = \frac{1}{RC}$, but in the question time constant is doubled so, frequency becomes half.

$$\omega_0 = \frac{1}{2RC}$$

$$Z_1 = 2R + \frac{1}{j\omega c} = 2(R - jR)$$

$$Z_2 = \frac{R \times \frac{1}{2j\omega c}}{R + \frac{1}{2j\omega c}} = \frac{\frac{R^2}{j}}{R + jR}$$

$$\beta = \frac{Z_2}{Z_1 + Z_2} = \frac{1}{5}$$

$$1 + \frac{R_1}{R_2} = 5 \Rightarrow R_1 = 4R_2$$

30. A source emits bit 0 with probability $\frac{1}{3}$ and bit 1 with probability $\frac{2}{3}$. The emitted bits are communicated to the receiver. The receiver decides for either 0 or 1 based on the received value R. It is given that the conditional density functions of R are as

$$f_{R|0}(r) = \begin{cases} \frac{1}{4}, & -3 \leq x \leq 1, \\ 0, & \text{otherwise,} \end{cases} \quad \text{and} \quad f_{R|1}(r) = \begin{cases} \frac{1}{6}, & -1 \leq x \leq 5, \\ 0, & \text{otherwise.} \end{cases}$$

The minimum decision error probability is

- (A) 0 (B) 1/12 (C) 1/9 (D) 1/6

Answer: (B)

31. For a silicon diode with long P and N regions, the acceptor and donor impurity concentrations are $1 \times 10^{17} \text{ cm}^{-3}$ and $1 \times 10^{15} \text{ cm}^{-3}$, respectively. The lifetimes of electrons in P region and holes in N region are both $100 \mu\text{s}$. The electron and hole diffusion coefficients are $49 \text{ cm}^2/\text{s}$ and $36 \text{ cm}^2/\text{s}$, respectively. Assume $kT/q = 26 \text{ mV}$, the intrinsic carrier concentration is $1 \times 10^{10} \text{ cm}^{-3}$ and $q = 1.6 \times 10^{-19} \text{ C}$. When a forward voltage of 208 mV is applied across the diode, the hole current density (in nA/cm^2) injected from P region to N regions is _____.

Answer:

32. For the NMOSFET in the circuit shown, the threshold voltage is V_{th} , where $V_{th} > 0$. The source voltage V_{ss} is varied from 0 to V_{DD} . Neglecting the channel length modulation, the drain current I_D as a function V_{ss} is represented by.

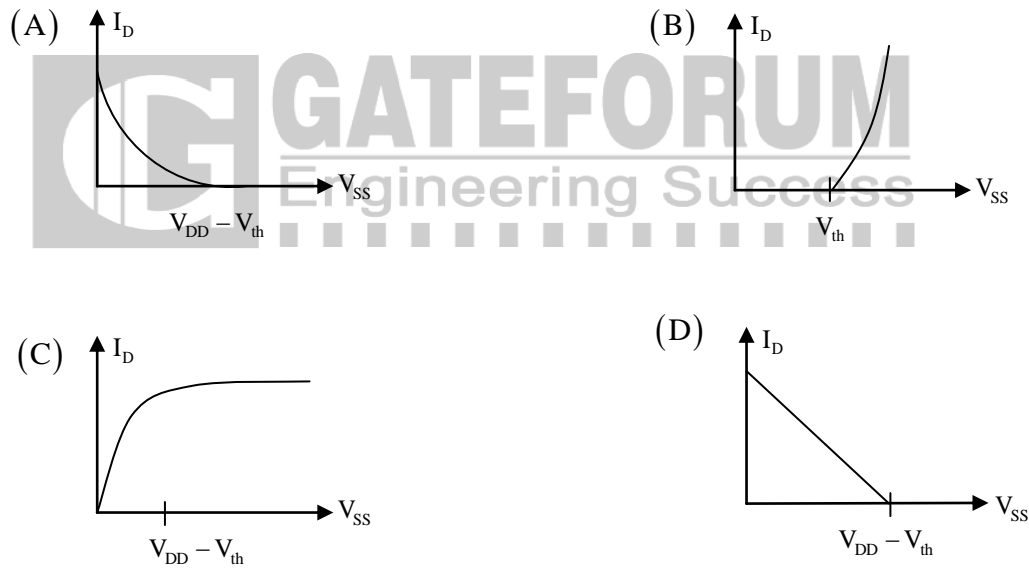
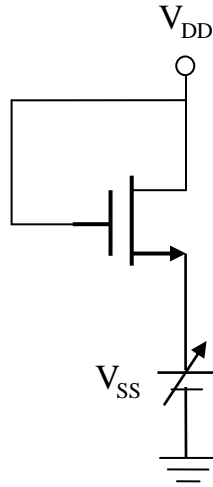

Answer: (A)

Exp: $V_{GS} = V_{DS}$

Hence MOS Transistor is in saturation.

In saturation,

$$I_D = k(V_{GS} - V_r)^2 = k(V_{DD} - V_{SS} - V_T)^2$$

As $V_{SS} \uparrow I_D \downarrow$ (Not linearly because square factor)

Hence option (A) correct

33. In the system shown in figure (a), $m(t)$ is a low-pass signal with bandwidth W Hz. The frequency response of the band-pass filter $H(f)$ is shown in figure (b). If it is desired that the output signal $z(t) = 10x(t)$, the maximum value of W (in Hz) should be strictly less than _____.

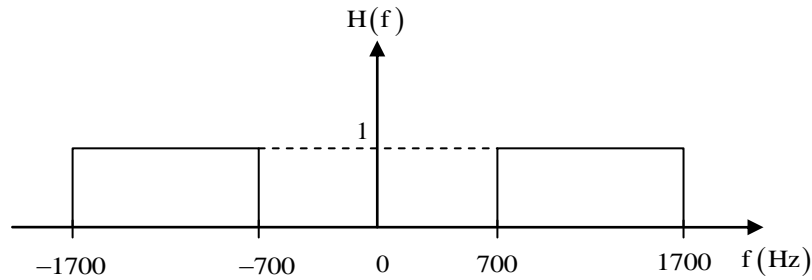
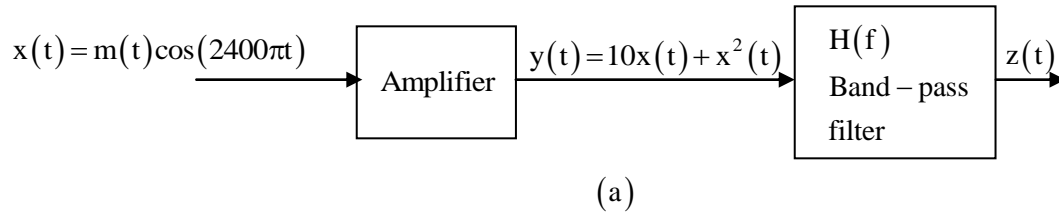

Answer: 350

Exp: $x(t) = m(t) \cdot \cos(2400\pi t)$

Spectrum of $x(t)$

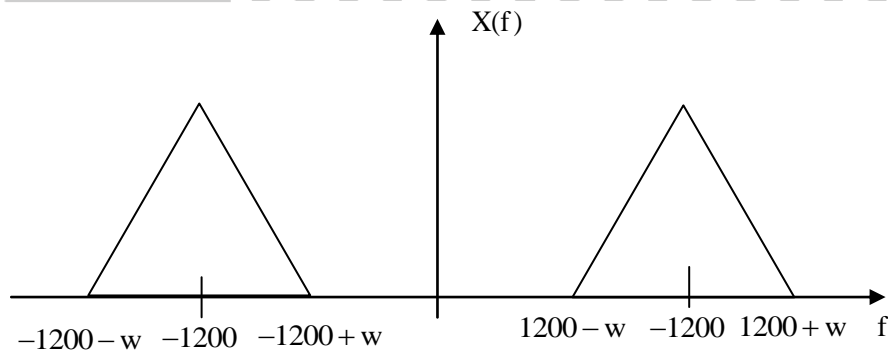

$$y(t) = 10x(t) + x^2(t)$$

Let us draw the spectrum of positive frequencies of $y(t)$.

$$y(t) = 10m(t)\cos(2400\pi t) + m^2(t)\cos^2(2400\pi t)$$

$$= 10m(t)\cos(2400\pi t) + m^2(t) \left[\frac{1 + \cos 4800\pi t}{2} \right]$$

$$y(t) = \frac{m^2(t)}{2} + 10m(t)\cos(2400\pi t) + \frac{m^2(t)}{2}\cos(4800\pi t)$$

$m^2(t) \longleftrightarrow$

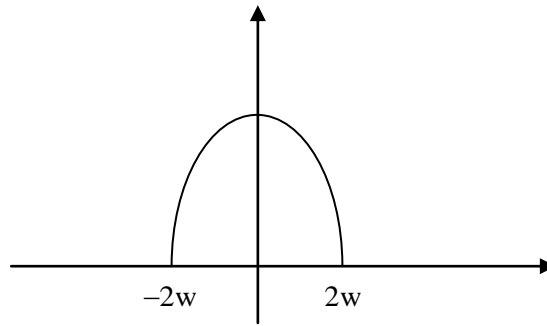

$y(t) \longleftrightarrow Y(f)$

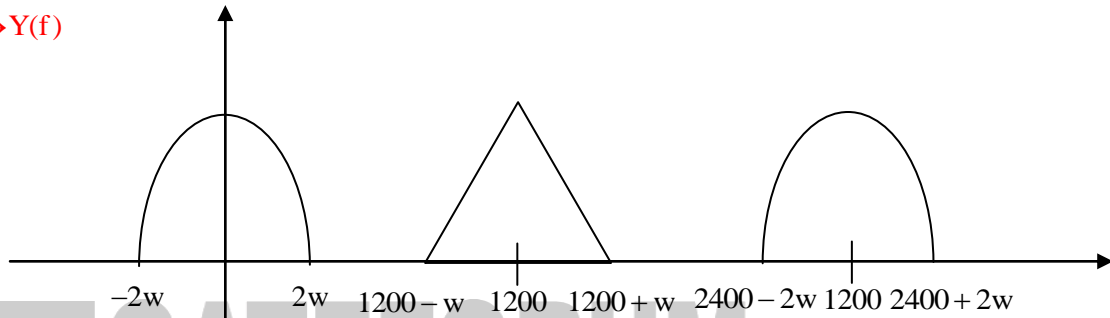

$\Rightarrow 2w < 700$

$2400 - 2w > 1700$

$\Rightarrow w < 350$

34. In the circuit shown, $I_1 = 80\text{mA}$ and $I_2 = 4\text{mA}$. Transistors T_1 and T_2 are identical. Assume that the thermal voltage V_T is 26mV at 27°C . At 50°C , the value of the voltage $V_{12} = V_1 - V_2$ (in mV) is _____.

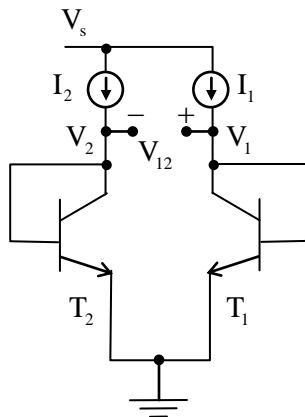

Answer: -19.2

Exp: $I_2 = I_S e^{V_{BE_2}/\eta V_T}$

$$V_{BE_2} = V_2$$

$$I_1 = I_S e^{V_{BE_1}/\eta V_T}$$

$$V_{BE} = V_1$$

$$\frac{I_1}{I_2} = e^{\frac{V_1 - V_2}{\eta V_T}}$$

$$V_T (\text{at } 50^\circ\text{C}) = \frac{50 + 273}{11,600} = 27.8 \text{ mV}$$

$$\frac{1}{2} = e^{\frac{V_1 - V_2}{27.8 \text{ mV}}}$$

$$V_1 - V_2 = -19.2 \text{ mV}$$

35. The electric field intensity of a plane wave traveling in free space is give by the following expression

$$E(x, t) = a_y 24\pi \cos(\omega t - k_0 x) (\text{V / m})$$

In this field, consider a square area 10cm x 10 cm on a plane $x + y = 1$. The total time-averaged power (in mW) passing through the square area is _____.

Answer: 53.3

Exp: $E(x, t) = 24\pi \cos(\omega t - k_0 x) \text{ V/m}$

$$\begin{aligned} P_{\text{avg}} &= \frac{1}{2} \frac{E_0^2}{\eta} a_x \\ &= \frac{1}{2} \frac{(24\pi)^2}{120\pi} a_x \\ &= 7.53 a_x \end{aligned}$$

$$\text{Power (P)} = \int_s P_{\text{avg}} \cdot ds$$

$$x + y = 1$$

$$\frac{a_x + a_y}{\sqrt{2}} \rightarrow \text{unit vector normal to the surface}$$

$$\begin{aligned} P &= \int_s 7.53 a_x \cdot \frac{a_x}{\sqrt{2}} dy dz \\ &= \frac{7.53}{\sqrt{2}} \times 10 \times 10 \times 10^{-2} \times 10^{-2} \end{aligned} \quad \left| \quad P = 53.3 \text{ mW} \right.$$

$$P = 53.3 \times 10^{-3} \text{ W}$$

36. The maximum area (in square units) of a rectangle whose vertices lie on the ellipse $x^2 + 4y^2 = 1$ is _____.

Answer: 1

Exp:

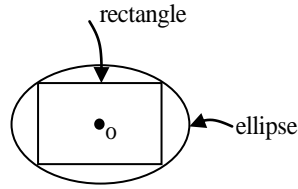

Let $2x, 2y$ be the length, breadth respectively of the rectangle inscribed in the ellipse $x^2 + 4y^2 = 1$, then

Area of the rectangle $(2x)(2y)$ i.e., $4xy$

Consider, $f = (\text{Area})^2$

$$= 16x^2y^2$$

$$= 4x^2(1-x^2) \left(\because y^2 = \frac{1-x^2}{4} \right)$$

$$f'(x) = 0 \Rightarrow x(1-2x^2) = 0 \Rightarrow x = \frac{1}{\sqrt{2}}$$

$$\therefore y^2 = \frac{1}{8} \Rightarrow y = \frac{1}{\sqrt{8}}$$

$$f''(x) = 8 - 48x^2 < 0 \text{ when } x = \frac{1}{\sqrt{2}}$$

$$\Rightarrow f \text{ is maximum at } x = \frac{1}{\sqrt{2}}$$

$$\therefore \text{Area is maximum and the maximum area is } 4 \left(\frac{1}{\sqrt{2}} \right) \left(\frac{1}{\sqrt{8}} \right) \text{ i.e., } 1$$

37. In the given circuit, the maximum power (in Watts) that can be transferred to the load R_L is

_____.

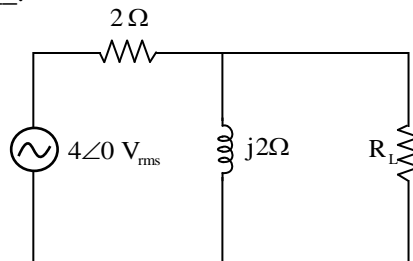

Answer: 1.66

$$\text{Exp: } V_{\text{Th(rms)}} = \frac{4 \times 2j}{2 + 2j} = 2\sqrt{2} \angle 45^\circ; V_{\text{Th(mq)}} = 2 \angle 4$$

$$Z_{Th} = 2 \parallel 2j = 1 + j$$

$$R_L = |Z_{Th}| = \sqrt{2} \Omega$$

Maximum power transfer to R_L is

$$P_{max} = |I|^2 \times R_L = \left| \frac{2\sqrt{2} \angle 45^\circ}{\sqrt{2} + 1 + j} \right|^2 \times \sqrt{2} = 1.66 \text{ W}$$

38. A lead compensator network includes a parallel combination of R and C in the feed-forward path. If the transfer function of the compensator is $G_c(s) = \frac{s+2}{s+4}$, the value of RC is _____.

Answer: 0.5

Exp: Given $G(s) = \frac{s+2}{s+4}$

$$\text{Zero} = 2 = \frac{1}{\tau} = \frac{1}{RC}$$

$$\text{Pole} = 4 = \frac{1}{\alpha\tau} = \frac{1}{RC\tau}$$

$$\text{So, } RC = 0.5$$

39. A MOSFET in saturation has a drain current of 1mA for $V_{DS} = 0.5\text{V}$. If the channel length modulation coefficient is 0.05 V^{-1} , the output resistance (in k Ω) of the MOSFET is _____.

Answer: 20

Exp: Under channel length modulation

$$I_D = I_{Dsat} (1 + \lambda V_{DS})$$

$$\frac{dI_D}{dV_{DS}} = \frac{1}{r_0} = \lambda I_{Dsat}$$

$$r_0 = \frac{1}{\lambda I_{Dsat}} = \frac{1}{0.05 \times 10^{-3}} = 20 \text{ k}\Omega$$

40. The built-in potential of an abrupt p-n junction is 0.75V. If its junction capacitance (C_j) at a reverse bias (V_R) of 1.25 V is 5pF, the value of C_j (in pF) when $V_R = 7.25\text{V}$ is _____.

Answer: 2.5

Exp: $C_j \propto \frac{1}{\sqrt{V_{bi} + V_R}}$

$$\frac{C_{2j}}{C_{1j}} = \sqrt{\frac{V_{bi} + V_{R_1}}{V_{bi} + V_{R_2}}}$$

$$C_{2j} = C_{1j} \sqrt{\frac{2}{8}} = \frac{C_{1j}}{2} = 2.5 \text{ pF}$$

So, answer is 2.5

41. In the circuit shown, assume that the opamp is ideal. The bridge output voltage V_o (in mV) for $\delta = 0.05$ is _____.

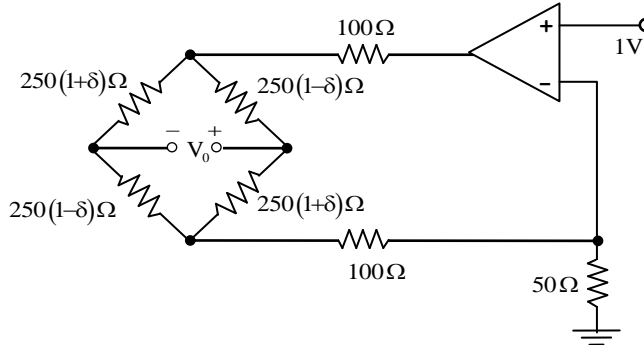

Answer: 250

Exp: $I_{50\Omega} = \frac{1}{50} \text{ A} = I_{100\Omega}$

$$V_o = \frac{1}{100} [250(1+\delta) - 250(1-\delta)]$$

$$= \frac{1}{100} \times 250 \times 2\delta$$

$$= \frac{1}{1000} \times 250 = 0.25 \text{ V}$$

$$= 250 \text{ mV}$$

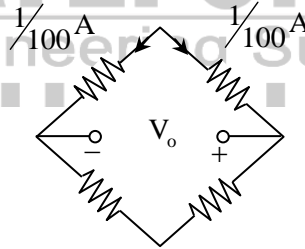

42. The damping ratio of a series RLC circuit can be expressed as

(A) $\frac{R^2 C}{2L}$ (B) $\frac{2L}{R^2 C}$ (C) $\frac{R}{2} \sqrt{\frac{C}{L}}$ (D) $\frac{2}{R} \sqrt{\frac{L}{C}}$

Answer: (C)

Exp: ' ξ ' = $\frac{1}{2Q}$ (In series RLC circuit)

$$= \frac{1}{2 \frac{1}{R} \sqrt{\frac{L}{C}}} = \frac{R}{2} \sqrt{\frac{C}{L}}$$

43. In the circuit shown, switch SW is closed at $t = 0$. Assuming zero initial conditions, the value of $v_c(t)$ (in Volts) at $t = 1$ sec is _____.

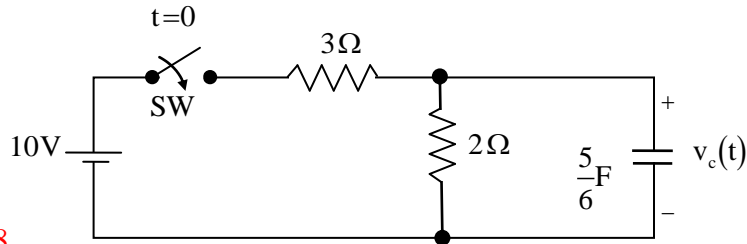

Answer: 2.528

Exp:

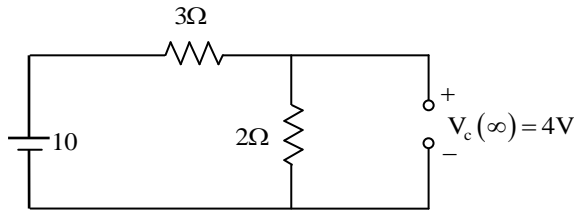

$$V_C(0^-) = 0V$$

At $t = \infty$, C is open circuit

$$V_C(\infty) = 4V$$

$$\tau = R_{th}C = (3 \parallel 2) \times \frac{5}{6} = \frac{6}{5} \times \frac{5}{6} = 1 \text{ sec}$$

$$V_C(t) = V_C(\infty) + [V_C(0^-) - V_C(\infty)]e^{-t/\tau}$$

$$= 4 - 4e^{-t}$$

$$V_C(1) = 4 - 4e^{-1} = 2.528V$$

44. Consider a uniform plane wave with amplitude (E_0) of 10V/m and 1.1GHz frequency travelling in air, and incident normally on a dielectric medium with complex relative permittivity (ϵ_r) and permeability (μ_r) as shown in the figure.

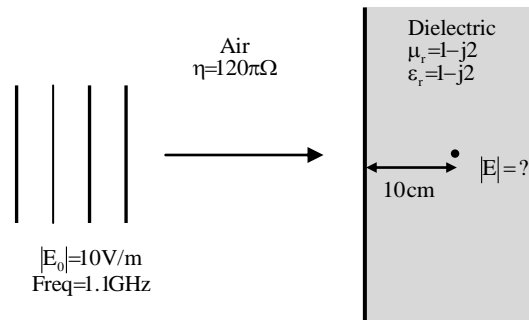

The magnitude of the transmitted electric field component (in V/m) after it has travelled a distance of 10 cm inside the dielectric region is _____.

Answer: 0.1

Exp:

(1)	(2) Dielectric ($\sigma = 0$)
<u>air</u>	$\mu_r = 1 - j2$
$\eta_1 = 120\pi\Omega$	$\epsilon_r = 1 - j2$
$E_1 = 10 \text{ V/m}$	$\eta_2 = 120\pi\Omega$

$$\eta_1 = \eta_2$$

So, $E_2 = E_1 = 10 \text{ V/m}$

$E_3 \rightarrow$ Electric field in the dielectric after travelling 10 cm

$$E_3 = E_2 e^{-\gamma z}$$

$$r = \alpha + j\beta = \sqrt{j\omega\mu(\sigma + j\omega\epsilon)}$$

$$\alpha + j\beta = j\omega\sqrt{\mu_0\epsilon_0}\sqrt{\mu_r\epsilon_r}$$

$$\alpha + j\beta = j\omega\sqrt{\mu_0\epsilon_0}(1 - j2)$$

$$= j\omega\sqrt{\mu_0\epsilon_0} + 2\omega\sqrt{\mu_0\epsilon_0}$$

$$\alpha = 2\omega\sqrt{\mu_0\epsilon_0} = \frac{2 \times 2\pi \times 1.1 \times 10^9}{3 \times 10^8} = 46.07$$

$$z = 10 \text{ cm}$$

$$E_3 = 10 e^{-10 \times 10^{-2} \times 46.07} = 10 e^{-4.6} = 0.1$$

45. A vector \vec{P} is given by $\vec{P} = x^3y\vec{a}_x - x^2y^2\vec{a}_y - x^2yz\vec{a}_z$. Which one of the following statements is TRUE?

- (A) \vec{P} is solenoidal, but not irrotational
- (B) \vec{P} is irrotational, but not solenoidal,
- (C) \vec{P} is neither solenoidal nor irrotational
- (D) \vec{P} is both solenoidal and irrotational

Answer: (A)

Exp: $P = x^3y\hat{a}_x - x^2y^2\hat{a}_y - x^2yz\hat{a}_z$
 $\nabla \cdot P = 3x^2y - 2x^2y - x^2y = 0$

It is solenoidal.

$$\nabla \times P = \begin{vmatrix} \hat{a}_x & \hat{a}_y & \hat{a}_z \\ \frac{\partial}{\partial x} & \frac{\partial}{\partial y} & \frac{\partial}{\partial z} \\ x^3y & -x^2y^2 & -x^2yz \end{vmatrix}$$

$$= \hat{a}_x(-x^2y) - \hat{a}_y(-2xyz) + \hat{a}_z(-2xy^2 - x^3) \neq 0$$

So P is solenoidal but not irrotational.

46. All the logic gates shown in the figure have a propagation delay of 20 ns. Let $A=C=0$ and $B=1$ until time $t=0$. At $t=0$, all the inputs flip (i.e., $A=C=1$ and $B=0$) and remain in that state. For $t > 0$, output $Z = 1$ for a duration (in ns) of

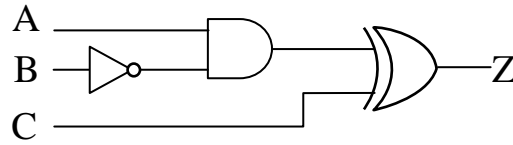

Answer: 40

Exp:

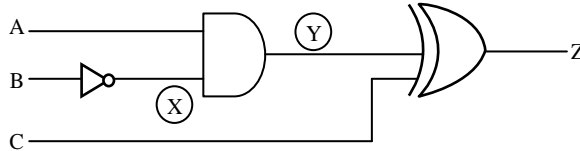

As per information given on question the waveforms of A, B, C are as follows

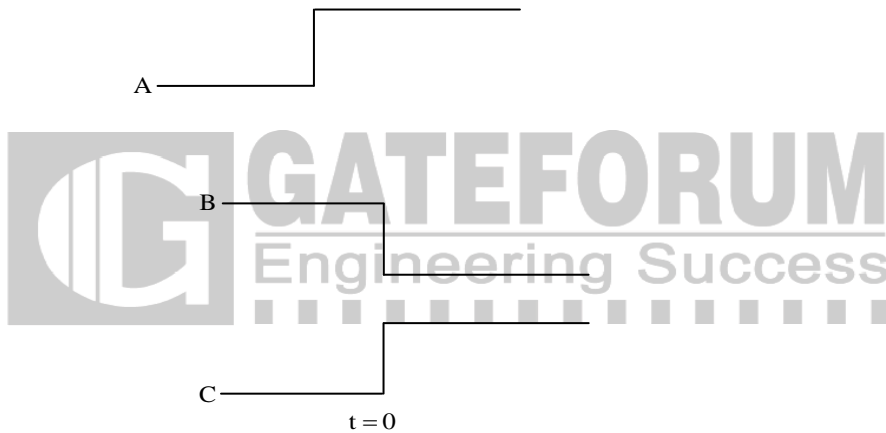

→ The logic to solve this question is first obtain X, Y waveform and using this obtain Z.

→ To obtain X, initially assume delay of NOT gate is 0 and draw its waveform and finally shift it by 20nsec to obtain actual X. Similar procedure to be followed for obtaining Y and Z i.e., first draw waveform with 0 delay and at the end shift by the amount of delay given in question.

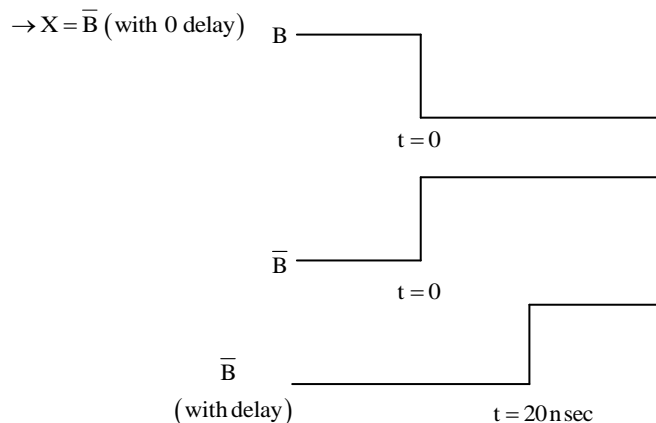

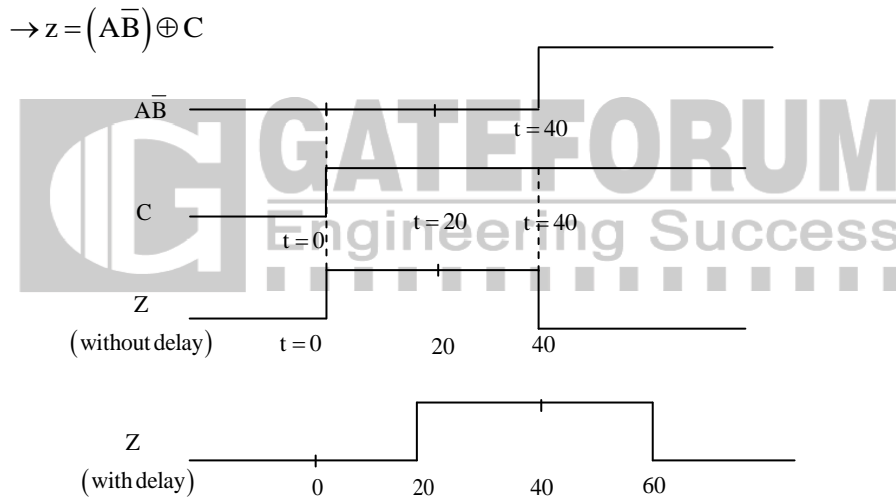
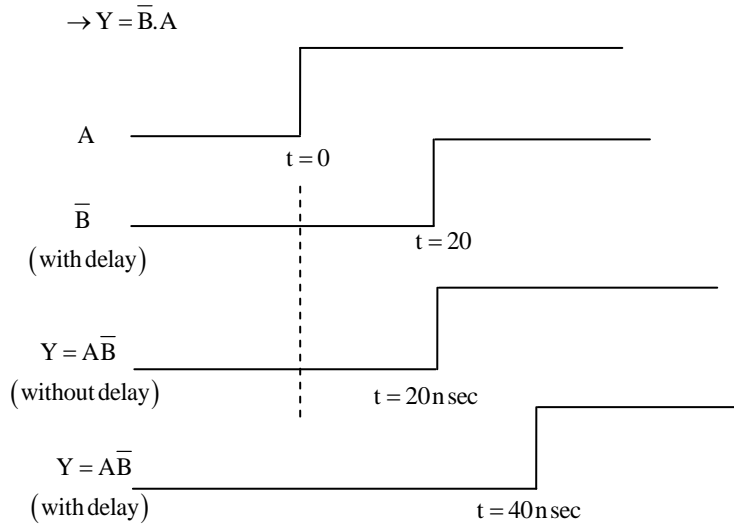

Clearly we can say that output is high during 20 nsec to 60 nsec i.e. a duration of 40 nsec

47. A plant transfer function is given as $G(s) = \left(K_p + \frac{K_I}{s} \right) \frac{1}{s(s+2)}$. When the plant operates in a unity feedback configuration, the condition for the stability of the closed loop system is
- (A) $K_p > \frac{K_I}{2} > 0$ (B) $2K_I > K_p > 0$ (C) $2K_I < K_p$ (D) $2K_I > K_p$

Answer: (A)

Exp: $G(s) = \frac{(sK_p + K_I)}{(s^3 + 2s^2)}$

C.E = $s^3 + 2s^2 + s^1K_p + K_I = 0$

R – H table

$$\begin{array}{r|l}
 s^3 & \begin{array}{ccc} 1 & K_p & 0 \end{array} \\
 s^2 & \begin{array}{ccc} 2 & K_I & 0 \end{array} \\
 s^1 & \begin{array}{ccc} (2K_p - K_I) & 0 & 0 \end{array} \\
 \hline
 & \begin{array}{ccc} 2 & & \end{array} \\
 s^0 & \begin{array}{ccc} K_I & & \end{array}
 \end{array}$$

For stable system

1st column elements must be positive

$$\Rightarrow K_I > 0$$

$$\left(\frac{2K_p - K_I}{2} \right) > 0$$

$$\therefore K_p > \frac{K_I}{2} > 0$$

48. A 3-input majority gate is defined by the logic function $M(a, b, c) = ab + bc + ca$. Which one of the following gates is represented by the function $M(\overline{M(a, b, c)}, M(a, b, \overline{c}), c)$?

- (A) 3-input NAND gate (B) 3-input XOR gate
(C) 3-input NOR gate (D) 3-input XNOR gate

Answer: (B) and (D)

Exp: $M(a, b, c) = ab + bc + ac = \sum m(3, 5, 6, 7)$

$$\overline{M(a, b, c)} = \sum m(0, 1, 2, 4) = X \text{ (let say for simplicity)}$$

$$M(a, b, \overline{c}) = ab + b\overline{c} + a\overline{c} = \sum m(2, 4, 6, 7) = Y \text{ (let)}$$

$$c = \sum m(1, 3, 5, 7) = z \text{ (let)}$$

$$f[\sqrt{M(a, b, c)}, M(a, b, \overline{c}), c] =$$

$$= f(x, y, z)$$

$$= xy + yz + zx$$

$$= [(\sum m(0, 1, 2, 4))(\sum m(2, 4, 6, 7))] + [(\sum m(2, 4, 6, 7)\sum m(1, 3, 5, 7))] + [\sum m(1, 3, 5, 7)\sum m(0, 1, 2, 4)]$$

$$= \sum m(2, 4) + \sum m(7) + \sum m(1)$$

$$= \sum m(1, 2, 4, 7) \left(\begin{array}{l} \because \text{AND operator is like intersection} \\ \text{OR operator is like union} \end{array} \right)$$

$$= A \oplus B \oplus C = A \odot B \odot C \text{ (standard result)}$$

Both options (D) and (B) are correct

49. The longitudinal component of the magnetic field inside an air-filled rectangular waveguide made of a perfect electric conductor is given by the following expression

$$H_z(x, y, z, t) = 0.1 \cos(25\pi x) \cos(30.3\pi y) \cos(12\pi \times 10^9 t - \beta z) \text{ (A/m)}$$

The cross-sectional dimensions of the waveguide are given as $a = 0.08\text{m}$ and $b = 0.033\text{m}$. The mode of propagation inside the waveguide is

- (A) TM_{12} (B) TM_{21} (C) TE_{21} (D) TE_{12}

Answer: (C)

Exp: $\frac{m\pi x}{a} = 25\pi x \Rightarrow m = 25a = 2$

$$\frac{n\pi y}{b} = 30.3\pi y \Rightarrow n = 30.3b = 1$$

Given is H_z means TE mode

$$\therefore \text{mode} = \text{TE}_{21}$$

50. The open-loop transfer function of a plant in a unity feedback configuration is given as

$$G(s) = \frac{K(s+4)}{(s+8)(s^2-9)}$$

The value of the gain $K(>0)$ for which $-1 + j2$ lies on the root locus

is _____.

Answer: 25.5

Exp: By magnitude condition

$$|G(s)H(s)|_{s=-1+j2} = 1$$

$$\text{So, } \frac{k|2j+3|}{|7+2j||2+2j||-4+2j|} = 1$$

$$K = \frac{\sqrt{20}\sqrt{8}\sqrt{53}}{\sqrt{13}}$$

$$= 25.5$$

So K value is = 25.5

51. Two sequences $[a, b, c]$ and $[A, B, C]$ are related as,

$$\begin{bmatrix} A \\ B \\ C \end{bmatrix} = \begin{bmatrix} 1 & 1 & 1 \\ 1 & W_3^{-1} & W_3^{-2} \\ 1 & W_3^{-2} & W_3^{-4} \end{bmatrix} \begin{bmatrix} a \\ b \\ c \end{bmatrix} \text{ where } W_3 = e^{j\frac{2\pi}{3}}$$

If another sequence $[p, q, r]$ is derived as,

$$\begin{bmatrix} p \\ q \\ r \end{bmatrix} = \begin{bmatrix} 1 & 1 & 1 \\ 1 & W_3^1 & W_3^2 \\ 1 & W_3^2 & W_3^4 \end{bmatrix} \begin{bmatrix} 1 & 0 & 0 \\ 0 & W_3^2 & 0 \\ 0 & 0 & W_3^4 \end{bmatrix} \begin{bmatrix} A/3 \\ B/3 \\ C/3 \end{bmatrix}$$

then the relationship between the sequences $[p, q, r]$ and $[a, b, c]$ is

- (A) $[p, q, r] = [b, a, c]$ (B) $[p, q, r] = [b, c, a]$
(C) $[p, q, r] = [c, a, b]$ (D) $[p, q, r] = [c, b, a]$

Answer: (C)

Exp: Consider,

$$\begin{bmatrix} 1 & 1 & 1 \\ 1 & w_3^1 & w_3^2 \\ 1 & w_3^2 & w_3^1 \end{bmatrix} \begin{bmatrix} 1 & 0 & 0 \\ 0 & w_3^2 & 0 \\ 0 & 0 & w_3^4 \end{bmatrix} = \begin{bmatrix} 1 & w_3^2 & w_3^4 \\ 1 & w_3^3 & w_3^6 \\ 1 & w_3^4 & w_3^5 \end{bmatrix}$$

$$\therefore w_3^4 = w_3^{(3+1)} = w_3^1 ; w_3^6 = w_3^3 = w_3^0 = 1 ; w_3^5 = w_3^2$$

$$\frac{1}{3} \begin{bmatrix} 1 & w_3^2 & w_3^1 \\ 1 & 1 & 1 \\ 1 & w_3^1 & w_3^2 \end{bmatrix} \begin{bmatrix} A \\ B \\ C \end{bmatrix} = \frac{1}{3} \begin{bmatrix} 1 & w_3^2 & w_3^1 \\ 1 & 1 & 1 \\ 1 & w_3^1 & w_3^2 \end{bmatrix} \begin{bmatrix} 1 & 1 & 1 \\ 1 & w_3^{-1} & w_3^{-2} \\ 1 & w_3^{-2} & w_3^{-1} \end{bmatrix} \begin{bmatrix} a \\ b \\ c \end{bmatrix}$$

$$\frac{1}{3} \begin{bmatrix} 1+w_3^2+w_3^1 & 1+w_3+w_3^{-1} & 1+w_3^0+w_3^0 \\ 1+1+1 & 1+w_3^{-1}+w_3^{-2} & 1+w_3^{-2}+w_3^{-1} \\ 1+w_3^1+w_3^2 & 1+w_3^0+w_3^0 & 1+w_3^{-1}+w_3^1 \end{bmatrix} \begin{bmatrix} a \\ b \\ c \end{bmatrix}$$

$$\therefore w_3 = e^{\frac{j2\pi}{3}},$$

$$w_3^2 + w_3^1 = w_3 + w_3^{-1} = w_3^{-1} + w_3^{-2} = -1$$

$$\therefore \begin{bmatrix} p \\ q \\ r \end{bmatrix} = \frac{1}{3} \begin{bmatrix} 0 & 0 & 3 \\ 3 & 0 & 0 \\ 0 & 3 & 0 \end{bmatrix} \begin{bmatrix} a \\ b \\ c \end{bmatrix} = \begin{bmatrix} c \\ a \\ b \end{bmatrix}$$

52. The solution of the differential equation $\frac{d^2y}{dt^2} + 2\frac{dy}{dt} + y = 0$ with $y(0) = y'(0) = 1$ is
- (A) $(2-t)e^t$ (B) $(1+2t)e^{-t}$ (C) $(2+t)e^{-t}$ (D) $(1-2t)e^t$

Answer: (B)

Exp: Differential equation is $(D^2+2D+1).y = 0$

$$D^2+2D+1 = 0 \Rightarrow (D+1)^2 = 0 \Rightarrow D = -1, -1$$

$$\therefore \text{solution is } y(t) = (c_1 + c_2 t)e^{-t} \rightarrow \text{C.F}$$

$$\Rightarrow y'(t) = c_2 e^{-t} + (c_1 + c_2 t)(-e^{-t})$$

$$y(0) = 1; y'(0) = 1 \text{ gives } c_1 = 1 \text{ and } c_2 + c_1(-1) = 1 \Rightarrow c_2 = 2$$

$$\therefore y(t) = (1+2t)e^{-t}$$

53. The pole-zero diagram of a causal and stable discrete-time system is shown in the figure. The zero at the origin has multiplicity 4. The impulse response of the system is $h[n]$. If $h[0] = 1$, we can conclude

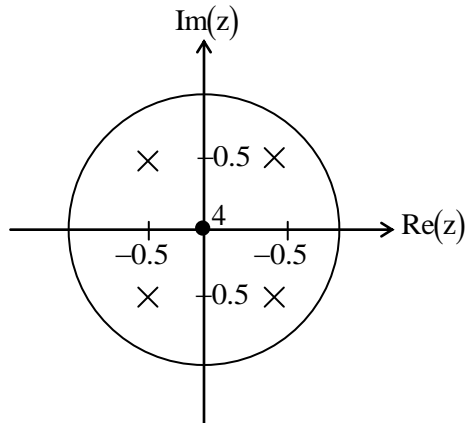

- (A) $h[n]$ is real for all n
- (B) $h[n]$ is purely imaginary for all n
- (C) $h[n]$ is real for only even n
- (D) $h[n]$ is purely imaginary for only odd n

Answer: (C)

54. Which one of the following graphs describes the function $f(x) = e^{-x}(x^2 + x + 1)$?

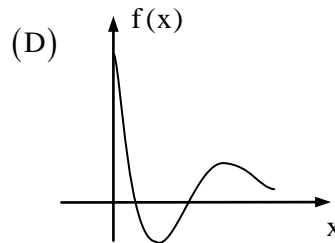
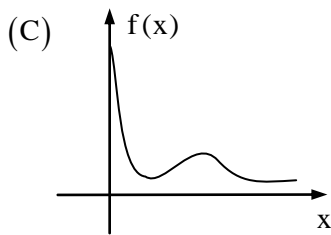
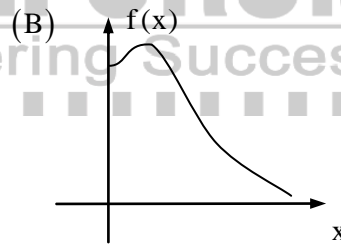
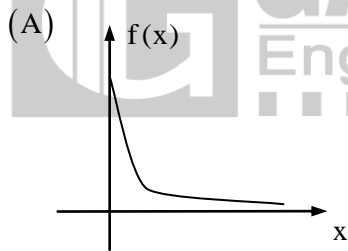

Answer: (B)

Exp: $f(1) = e^{-1}(1^2 + 1 + 1)$

$f(0) = 1$

$f(0.5) = 1.067$

For positive values of x , function never goes negative.

55. The Boolean expression $F(X, Y, Z) = \bar{X}Y\bar{Z} + X\bar{Y}\bar{Z} + XY\bar{Z} + XYZ$ converted into the canonical product of sum (POS) form is

(A) $(X + Y + Z)(X + Y + \bar{Z})(X + \bar{Y} + \bar{Z})(\bar{X} + Y + \bar{Z})$

(B) $(X + \bar{Y} + Z)(\bar{X} + Y + \bar{Z})(\bar{X} + \bar{Y} + Z)(\bar{X} + \bar{Y} + \bar{Z})$

(C) $(X + Y + Z)(\bar{X} + Y + \bar{Z})(X + \bar{Y} + Z)(\bar{X} + \bar{Y} + \bar{Z})$

(D) $(X + \bar{Y} + \bar{Z})(\bar{X} + Y + Z)(\bar{X} + \bar{Y} + Z)(X + Y + Z)$

Answer: (A)

Exp: Given minterms are:

$$F(X, Y, Z) = \bar{X}Y\bar{Z} + X\bar{Y}\bar{Z} + XY\bar{Z} + XYZ$$

$$\text{So, maxterm is } F(X, Y, Z) = \pi m(0, 1, 3, 5)$$

$$\text{POS} = (X + Y + Z)(X + Y + \bar{Z})(X + \bar{Y} + \bar{Z})(\bar{X} + Y + \bar{Z})$$

